

NOTES FOR STANDARD CONSTRUCTION:  
 ...MEETS FMCSA REQUIREMENTS.  
 ...PRESSURE TESTED @ 5psi  
 ...INTERIOR FREE OF FOREIGN MATTER.  
 ...FILLER CAP, DRAIN PLUG & VENT PROVIDED.  
 ...REPLACEABLE DRAW TUBE  
 ...ALUMINUM CONSTRUCTION:  
 5052-H32 ALUMINUM, BRIGHT FINISH  
 HEADS ARE 0.100" & SHELL IS 0.187"  
 ...ALL OPENINGS PLUGGED PRIOR TO SHIPPING

ITEM NO.	PART NUMBER	DESCRIPTION	QTY.
1	116-0322	1/8" Aluminum Wrap	1
2	160-0011	14x25 Head	2
3	260-0005	1/2" FNPT Aluminum weld flange	4
4	265-0010	Aluminum Float Riser	1
5	316-0004	2" Aluminum Filler Neck	1
6	458-0100	1/2" NPT Ball Check Drain Plug	1
7	490-0014-Z	1/2" NPT Down Tube	1
8	454-0937	1/2" NPT Ball Check Vent	1
9	452-0998	2" Thermal Relief Fuel Cap	1
10	267-0006	Step Assembly	1

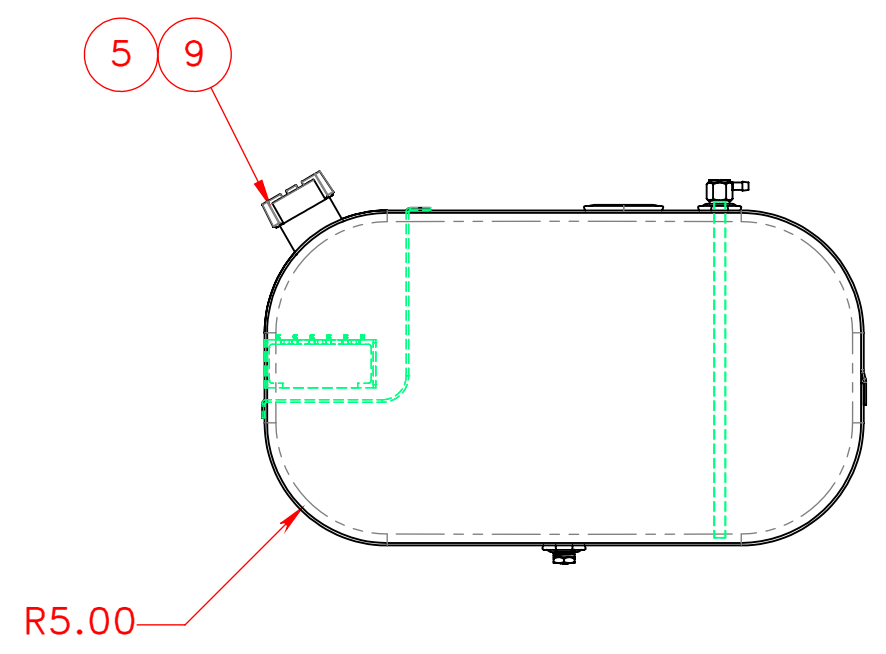
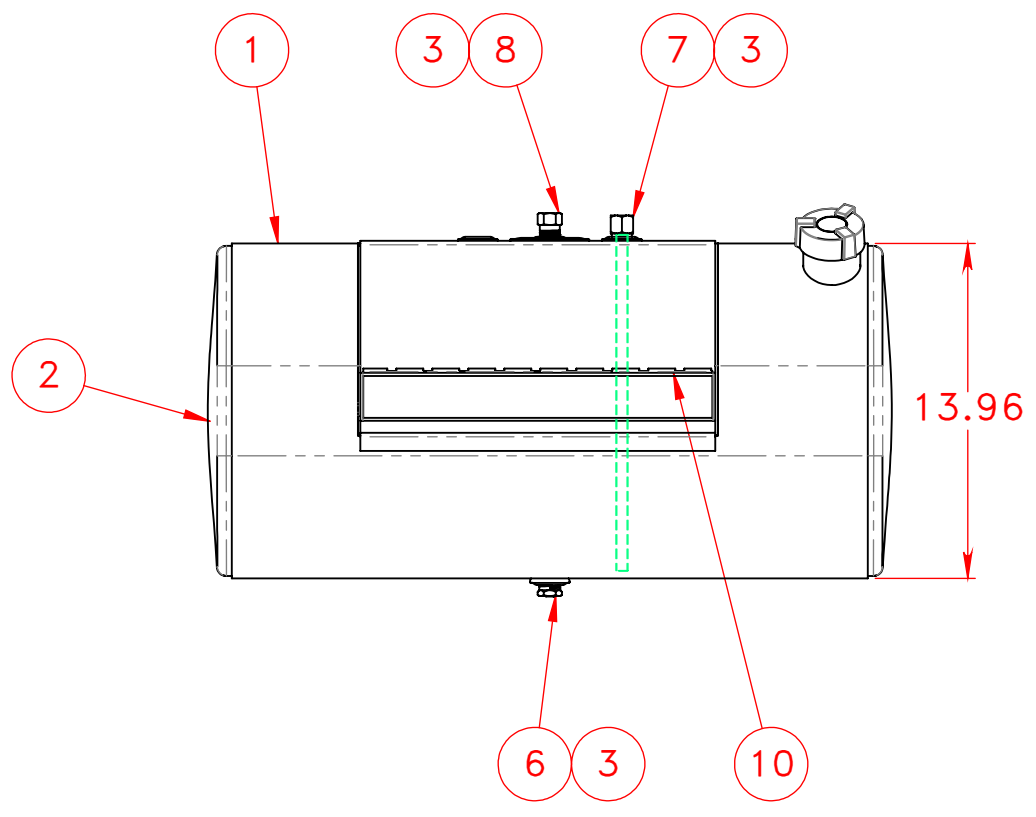

PROPRIETARY AND CONFIDENTIAL  
 THE INFORMATION CONTAINED IN THIS DRAWING IS THE SOLE PROPERTY OF PROPOWER MFG. INC. ANY REPRODUCTION IN PART OR AS A WHOLE WITHOUT THE WRITTEN PERMISSION OF PROPOWER MFG. INC. IS PROHIBITED.

UNLESS OTHERWISE SPECIFIED:	DRAWN	NAME	DATE
DIMENSIONS ARE IN INCHES	CHECKED	A.B	05/07/13
TOLERANCES:	ENG APPR.		
FRACTIONAL ± 1/16	MFG APPR.		
ANGULAR: MACH ± 1° BEND ± 1°	Q.A.		
TWO PLACE DECIMAL ± .06	COMMENTS:		
THREE PLACE DECIMAL ± .031			
INTERPRET GEOMETRIC TOLERANCING PER:			
MATERIAL			
ALUMINUM			
FINISH			
DO NOT SCALE DRAWING			

PROPOWER MFG. INC.  
 WINDSOR, ONTARIO, CANADA  
 Ph: 519-737-1197 Fax: 519-737-1918  
 TOLL FREE 1-877-741-2365 Web: metaltanks.com

TITLE:  
 FD-R14-25RFA28  
 35 US GROSS GALLONS  
 32 USEBLE GALLONS  
 DIESEL FUEL TANK

SIZE DWG. NO. REV  
**C** **15238**

SCALE: 1:8 WEIGHT: 31 lbs SHEET 1 OF 2