

ITEM NO.	PART NUMBER	DESCRIPTION	QTY.
1	116-0022	1/8" Auminum Wrap	1
2	266-0001	Aluminum Diffuser Baffle	1
3	266-0007	Anti Vortex & Rein Plate	2
4	160-0021	24" Aluminum Head	2
5	265-0099	Aluminum Hydraulic Riser	1
6	260-0006	3/4" FNPT Aluminum weld flange	2
7	474-0001	3/4" NPT Auxillary Breather	1
8	478-0001	3/4" NPT Magnetic Plug	1
9	472-0001	Filler Breather Assembly	1
10	724-0044	24" J Bracket & Strap	2
11	260-0011	1 1/2" Aluminum FNPT weld flange	2
12	260-0010	1 1/2" NPT Aluminum weld flange	1

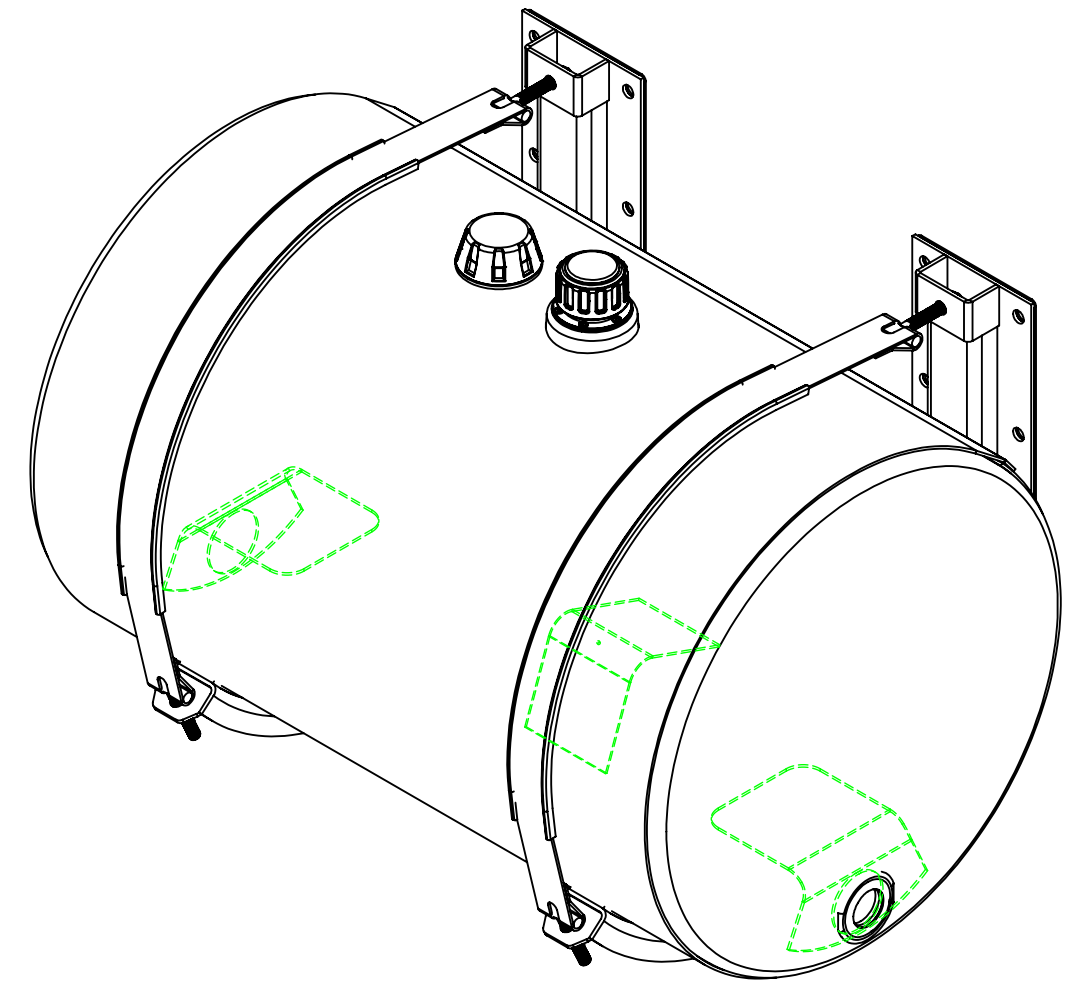

NOTES FOR STANDARD CONSTRUCTION:
 ...PRESSURE TESTED @ 5psi.
 ...INTERIOR FREE OF FOREIGN MATTER.
 ...FILLER CAP, MAGNETIC DRAIN PLUG PROVIDED.
 ...FULL BAFFLE(S) WHERE SHOWN.
 ...ALUMINUM CONSTRUCTION:
 5052-H32 ALUMINUM, BRIGHT FINISH
 HEADS ARE .100" & SHELL IS .125".
 ...ALL OPENINGS PLUGGED PRIOR TO SHIPPING

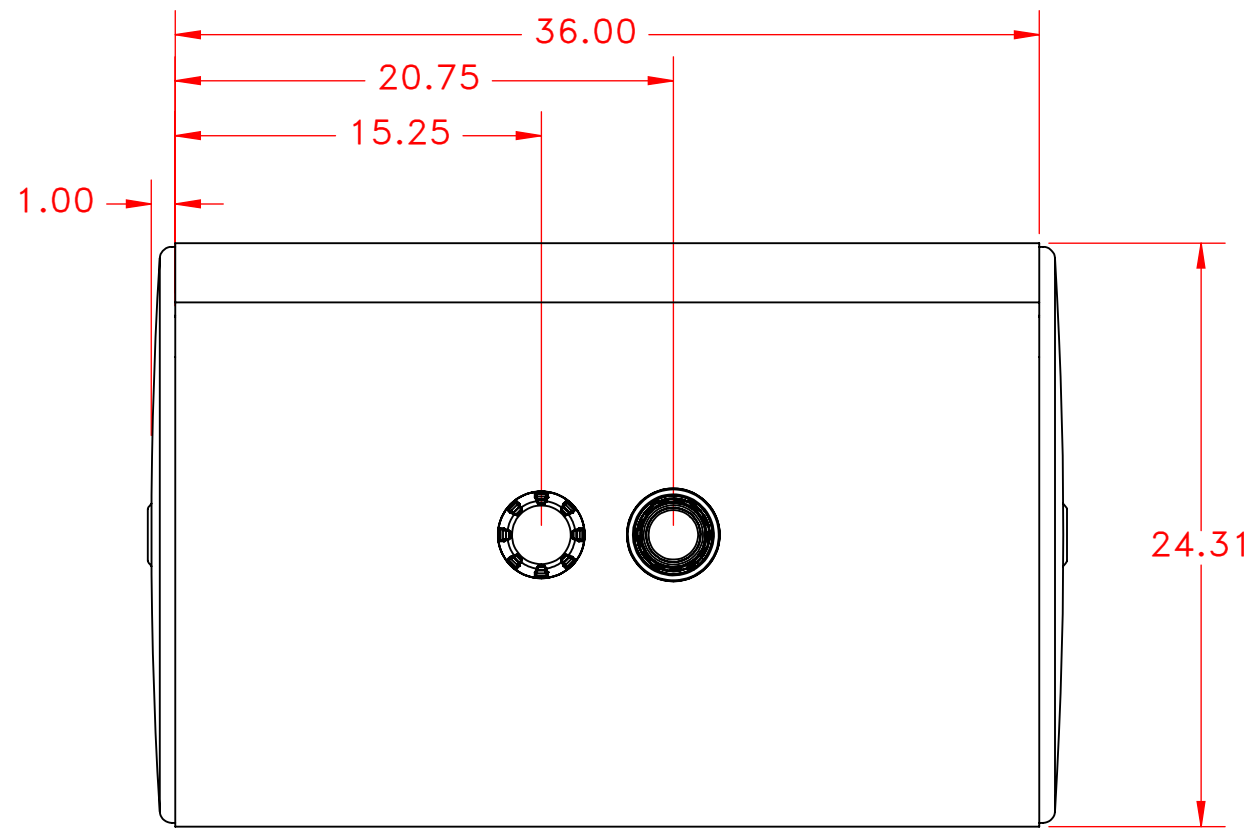
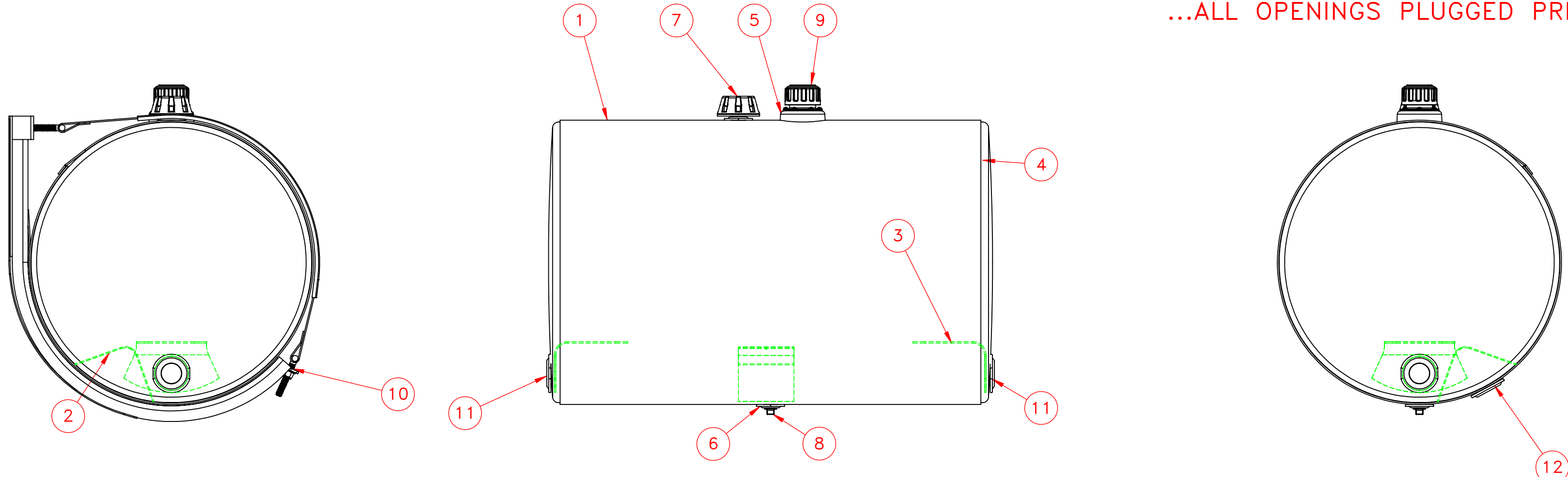

NOTES

- USE 2 BRACKETS
- EACH BRACKET IS COMPLETE WITH 1/8 X 2" NEOPRENE PAD TO BE PLACED BETWEEN THE TANK & BRACKET.
- STRAPS ARE 2" CARBON STEEL WITH NEOPRENE CHANNEL. SELF LOCKING, PLATED NUTS AND FLAT WASHERS PROVIDED.

PROPRIETARY AND CONFIDENTIAL
 THE INFORMATION CONTAINED IN THIS DRAWING IS THE SOLE PROPERTY OF PROPOWER MFG. INC. ANY REPRODUCTION IN PART OR AS A WHOLE WITHOUT THE WRITTEN PERMISSION OF PROPOWER MFG. INC. IS PROHIBITED.

UNLESS OTHERWISE SPECIFIED:	DRAWN	NAME	DATE
DIMENSIONS ARE IN INCHES	A.B		05/28/08
TOLERANCES:	CHECKED		
FRACTIONAL ±	ENG APPR.		
ANGULAR: MACH ± BEND ±	MFG APPR.		
TWO PLACE DECIMAL ±	Q.A.		
THREE PLACE DECIMAL ±	COMMENTS:		
INTERPRET GEOMETRIC TOLERANCING PER:			
MATERIAL	ALUMINUM		
FINISH			
DO NOT SCALE DRAWING	THIRD ANGLE PROJECTION		

PROPOWER MFG. INC. OLDCASTLE, ONTARIO, CANADA Ph: 519-737-1197 Fax: 519-737-1918 TOLL FREE 1877-7412364 Web: metaltanks.com	
TITLE: 24CWA38K 70usg HYDRAULIC RESERVOIR	
SIZE DWG. NO.	REV
C 8450	
SCALE: 1:12.WEIGHT:	SHEET 1 OF 2