

ITEM NO.	PART NUMBER	DESCRIPTION	QTY.
1	116-0818	1/8" Auminum Wrap	1
2	162-0054	24" Baffle	1
3	160-0021	24" Aluminum Head	2
4	266-0007	Anti Vortex & Rein Plate	2
5	266-0001	Aluminum Diffuser	1
6	260-0006	3/4" FNPT Aluminum weld flange	2
7	260-0011	1 1/2" Aluminum FNPT weld flange	2
8	260-0012	2" FNTP Aluminum weld flange	1
9	265-0099	Aluminum Hydraulic Riser	1
10	478-0001	3/4" NPT Magnetic Plug	1
11	474-0001	3/4" NPT Auxillary Breather	1
12	472-0001	Filler Breather Assembly	1
13	724-0044	24" J Bracket & Strap	2

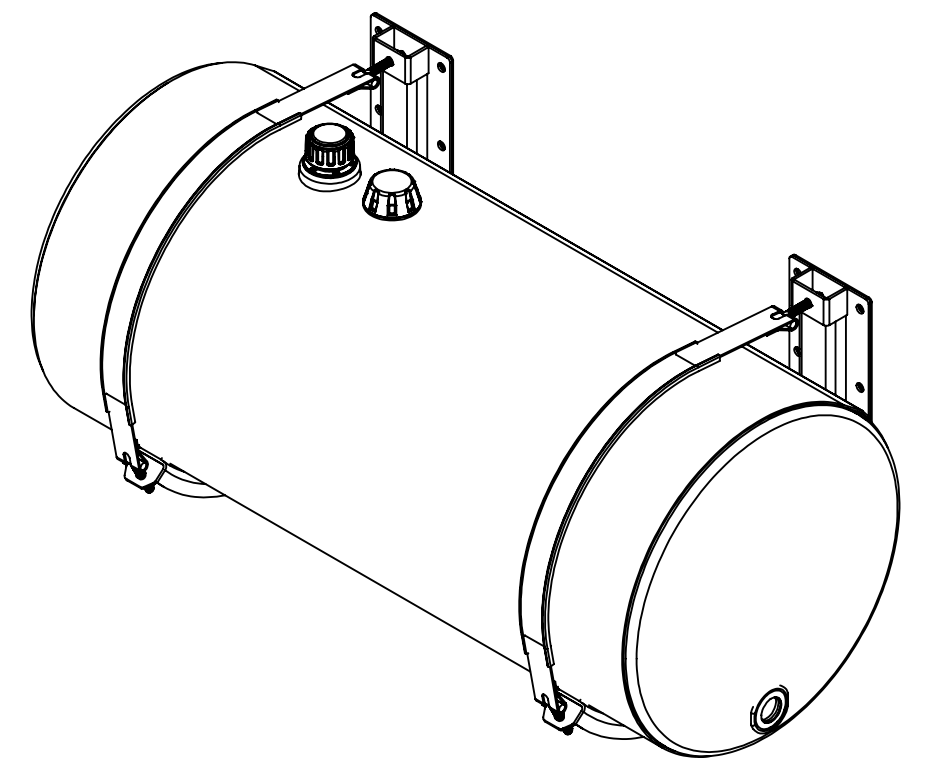

NOTES FOR STANDARD CONSTRUCTION:
 ...PRESSURE TESTED @ 5psi.
 ...INTERIOR FREE OF FOREIGN MATTER.
 ...FILLER CAP, MAGNETIC DRAIN PLUG PROVIDED.
 ...ALUMINUM CONSTRUCTION:
 5052-H32 ALUMINUM, BRIGHT FINISH
 HEADS ARE .100" & SHELL IS .125".
 ...ALL OPENINGS PLUGGED PRIOR TO SHIPPING

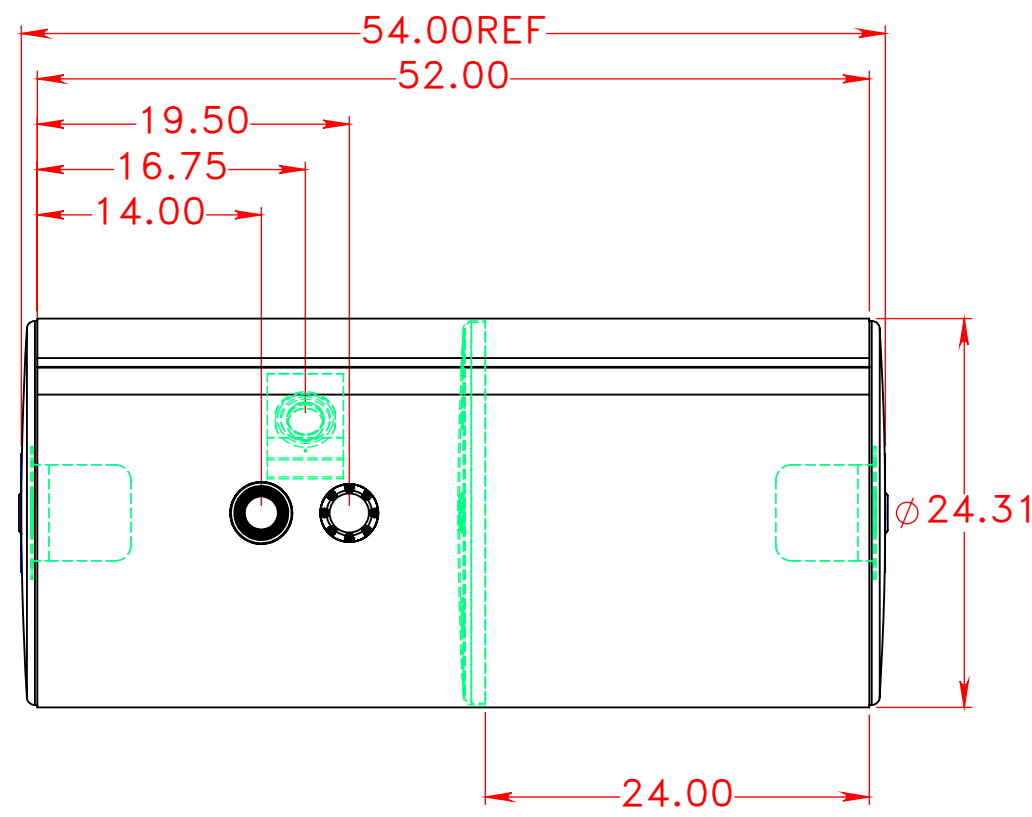
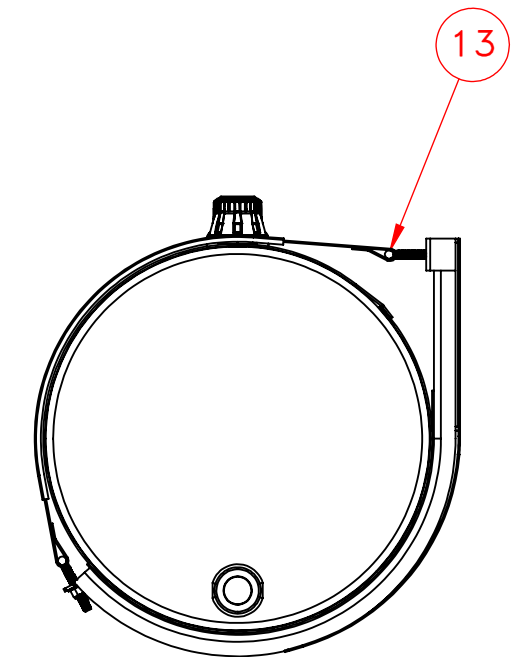
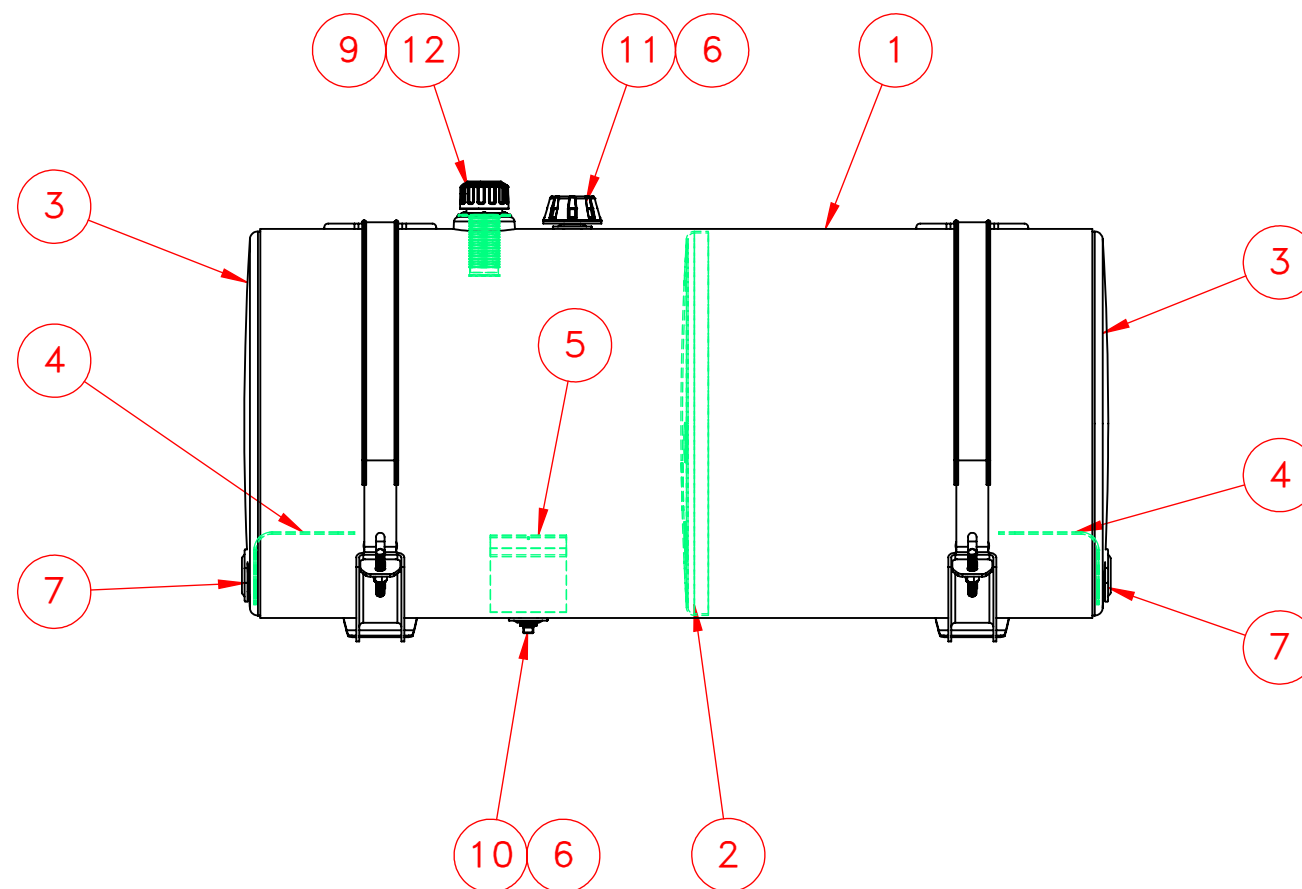
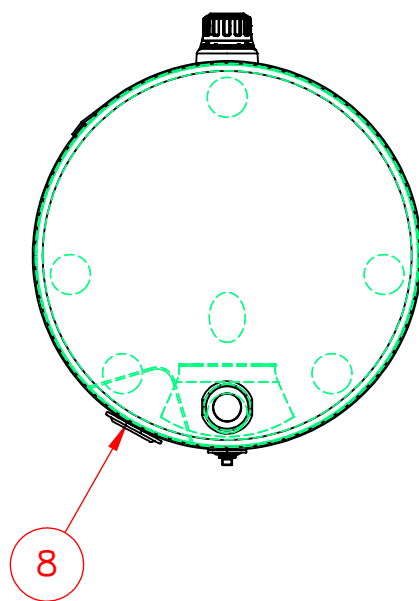

NOTES

- USE 2 BRACKETS
- EACH BRACKET IS COMPLETE WITH 1/8 X 2" NEOPRENE PAD TO BE PLACED BETWEEN THE TANK & BRACKET.
- STRAPS ARE 2" CARBON STEEL WITH NEOPRENE CHANNEL. SELF LOCKING, PLATED NUTS AND FLAT WASHERS PROVIDED.

PROPRIETARY AND CONFIDENTIAL
 THE INFORMATION CONTAINED IN THIS DRAWING IS THE SOLE PROPERTY OF PROPOWER MFG. INC. ANY REPRODUCTION IN PART OR AS A WHOLE WITHOUT THE WRITTEN PERMISSION OF PROPOWER MFG. INC. IS PROHIBITED.

UNLESS OTHERWISE SPECIFIED: DIMENSIONS ARE IN INCHES TOLERANCES: FRACTIONAL ± 1/16 ANGULAR: MACH ± 1° BEND ± 1° TWO PLACE DECIMAL ± .06 THREE PLACE DECIMAL ± .031	DRAWN	NAME	DATE	PROPOWER MFG. INC. WINDSOR, ONTARIO, CANADA Ph: 519-737-1197 Fax: 519-737-1918 TOLL FREE 1877-7412365 Web: metaltanks.com
	CHECKED	A.B	04/28/16	
	ENG APPR.			
	MFG APPR.			
INTERPRET GEOMETRIC TOLERANCING PER: MATERIAL	COMMENTS:			TITLE:
FINISH	ALUMINUM			24CWA54K 100 US gal HYDRAULIC RESERVOIR
DO NOT SCALE DRAWING	THIRD ANGLE PROJECTION			SIZE DWG. NO. REV C 20429
SCALE: 1:8 WEIGHT:				SHEET 1 OF 2