

NOTES FOR STANDARD CONSTRUCTION:
 ...PRESSURE TESTED @ 5psi.
 ...INTERIOR FREE OF FOREIGN MATTER.
 ...FILLER CAP, MAGNETIC DRAIN PLUG PROVIDED.
 ...FULL BAFFLE(S) WHERE SHOWN.
 ...ALUMINUM CONSTRUCTION;
 TOP WRAP IS POLISHED CHECKER PLATE
 BOTTOM WRAP IS .125".
 5052-H32 ALUMINUM, BRIGHT FINISH
 HEADS ARE 3/16".
 ...ALL OPENINGS PLUGGED PRIOR TO SHIPPING

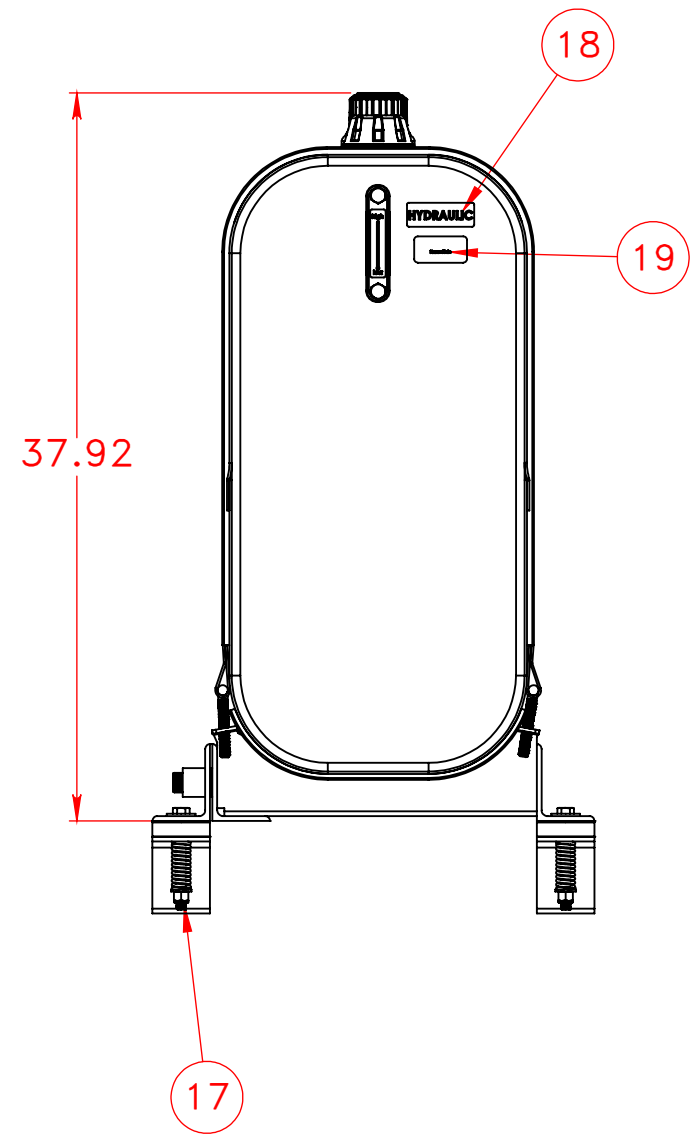

ITEM NO.	PART NUMBER	DESCRIPTION	QTY.
1	116-0051	Bottom 1/8" Auminum Wrap	1
2	266-0041	BCA75 Ladder Style Rein	1
3	160-0140	3/16" Aluminum Head	1
4	160-0141	3/16" Aluminum Head	1
5	515-1008	1/2"-13 Aluminum Hex Weld-Nut	2
6	113-0009	Top Wrap 1/8" Aluminum Checker Plate	1
7	260-0011	1 1/2" Aluminum FNPT weld flange	2
8	260-0006	3/4" FNPT Aluminum weld flange	2
9	265-0099	Aluminum Hydraulic Riser	1
10	478-0001	3/4" NPT Magnetic Plug	1
11	476-0010	5" Temperature/Sight Gauge	1
12	472-0001	Filler Breather Assembly	1
13	474-0001	3/4" NPT Auxillary Breather	1
14	266-0001	Aluminum Diffuser	2
15	724-0099	BCX Bracket	1
16	726-0071	Strap With Rubber & Hardware	2
17	722-0003	Spring Mounting Kit	1
18	602-0010	Hydraulic Only	1
19	602-0011	Hydraulic Reservoir Name plate	1

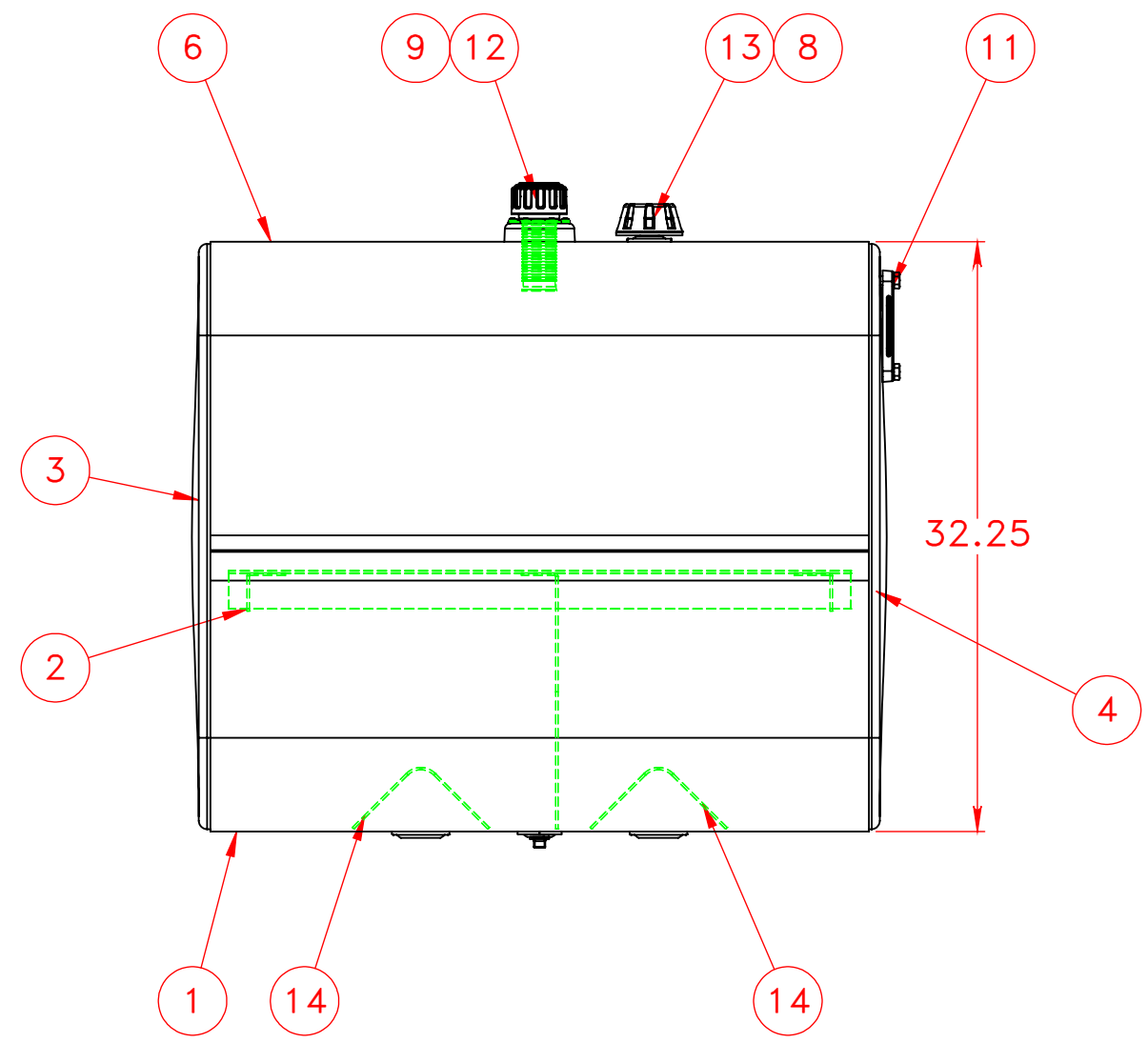
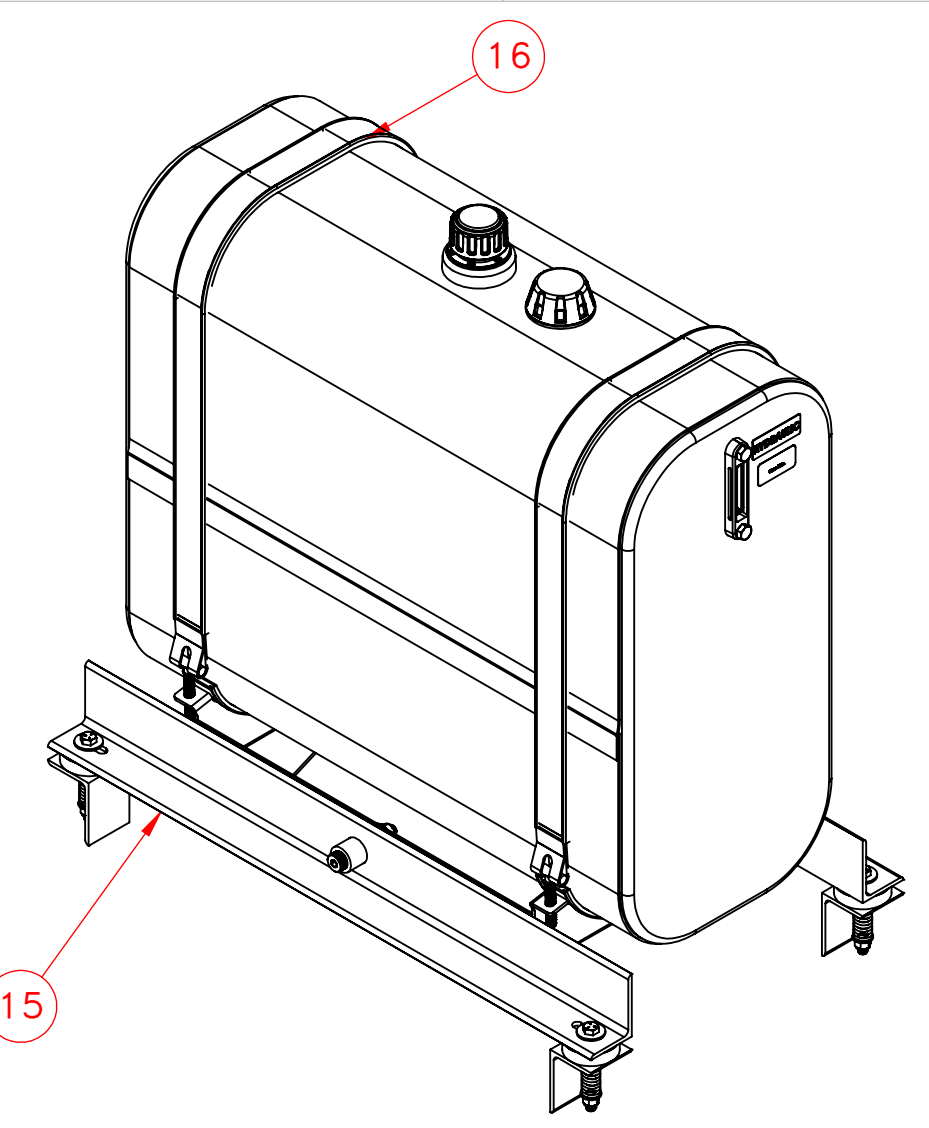
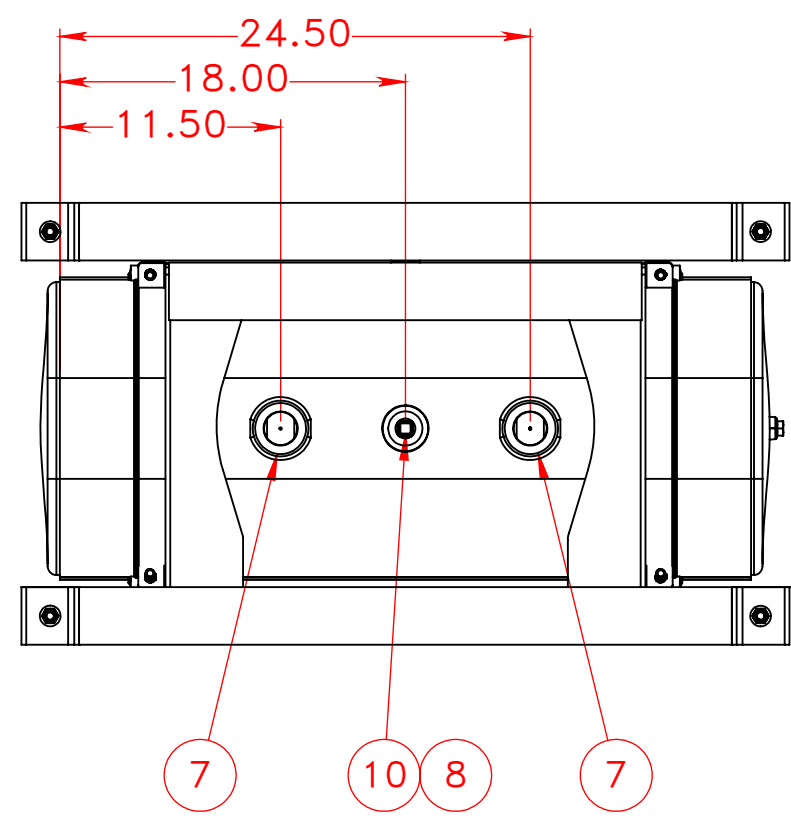

PROPRIETARY AND CONFIDENTIAL
 THE INFORMATION CONTAINED IN THIS DRAWING IS THE SOLE PROPERTY OF PROPOWER MFG. INC. ANY REPRODUCTION IN PART OR AS A WHOLE WITHOUT THE WRITTEN PERMISSION OF PROPOWER MFG. INC. IS PROHIBITED.

UNLESS OTHERWISE SPECIFIED:	DRAWN	NAME	DATE
DIMENSIONS ARE IN INCHES	CHECKED	Admin	10/04/21
TOLERANCES:	ENG APPR.		
FRACTIONAL ± 1/16	MFG APPR.		
ANGULAR: MACH ± 1° BEND ± 1°	Q.A.		
TWO PLACE DECIMAL ± .06	COMMENTS:		
THREE PLACE DECIMAL ± .031	INTERPRET GEOMETRIC TOLERANCING PER:		
	MATERIAL	ALUMINUM	
	FINISH		
DO NOT SCALE DRAWING	THIRD ANGLE PROJECTION		

PROPOWER MFG. INC.
 WINDSOR, ONTARIO, CANADA
 Ph: 519-737-1197 Fax: 519-737-1918
 TOLL FREE 1877-7412365 Web: metaltanks.com

TITLE:
BCA75X
75 US gal HYDRAULIC RESERVOIR

SIZE DWG. NO. REV
C 28026

SCALE: 1:10 WEIGHT: 60 LBS SHEET 1 OF 11