

NOTES FOR STANDARD CONSTRUCTION:
 ...PRESSURE TESTED @ 5psi
 ...INTERIOR FREE OF FOREIGN MATTER.
 ...FILLER CAP, TEMPERATURE-SIGHT GAUGE
 MAGNETIC DRAIN PLUG PROVIDED.
 ...ALL OPENINGS PLUGGED FOR SHIPPING
 ...ALUMINUM CONSTRUCTION:
 5052-H32 ALUMINUM, 0.125" BODY WITH 0.1875" HEADS.

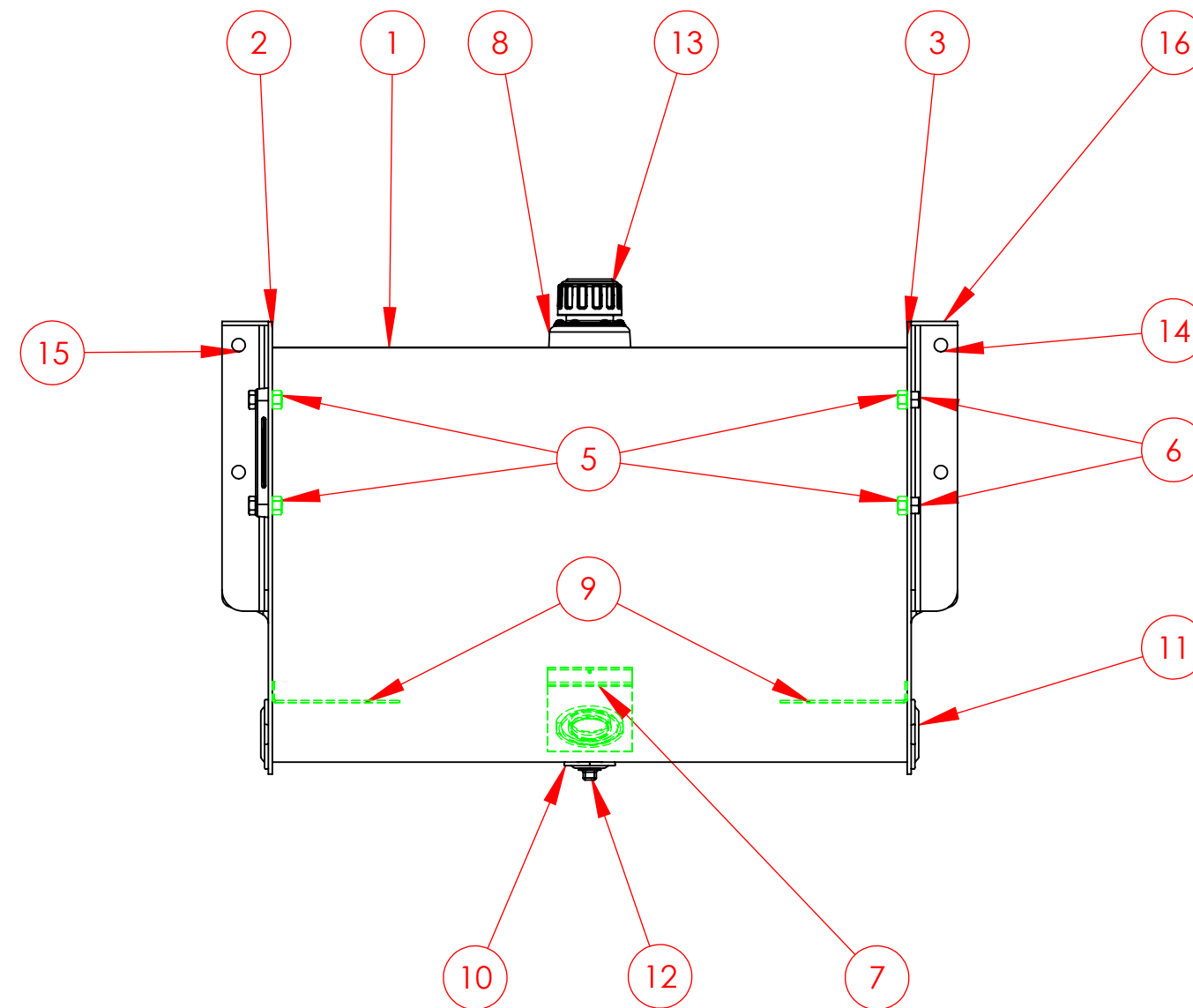
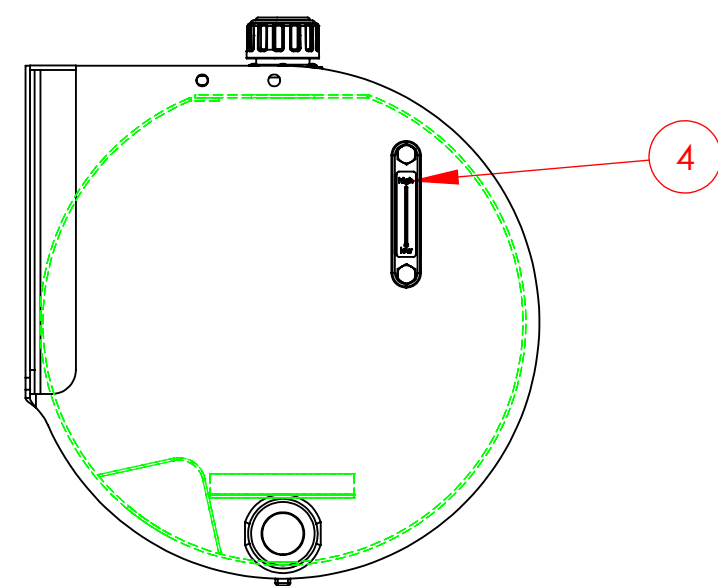

ITEM NO.	DESCRIPTION	QTY.
1	Fmda 40	1
2	Left FMA Head	1
3	Right FMA Head	1
4	5" Sight Gauge	1
5	WELD HNUT 0.5-13-D-N	4
6	HBOLT 0.5000-13x1.5x1.25-N	2
7	Diffuser Baffle	1
8	Hydraulic Filler Weld Riser	1
9	Anti Vortex	2
10	3/4" FNPT weld flange	1
11	1 1/2" FNPT weld flange	3
12	3/4" Magnetic Drain	1
13	Filler Breather Assembly	1
14	Right Angle	1
15	Left Angle	1
16	Gusset	2

PROPRIETARY AND CONFIDENTIAL
 THE INFORMATION CONTAINED IN THIS DRAWING IS THE SOLE PROPERTY OF PROPOWER MFG. INC. ANY REPRODUCTION IN PART OR AS A WHOLE WITHOUT THE WRITTEN PERMISSION OF PROPOWER MFG. INC. IS PROHIBITED.

UNLESS OTHERWISE SPECIFIED:	DRAWN	NAME	DATE
DIMENSIONS ARE IN INCHES	CHECKED	A.B	01/29/09
TOLERANCES:	ENG APPR.		
FRACTIONAL ±	MFG APPR.		
ANGULAR: MATCH ±	Q.A.		
TWO PLACE DECIMAL ±	COMMENTS:		
THREE PLACE DECIMAL ±			
INTERPRET GEOMETRIC TOLERANCING PER:			
MATERIAL	ALUMINUM		
FINISH			
DO NOT SCALE DRAWING	THIRD ANGLE PROJECTION		

PROPOWER MFG. INC. OLDCASTLE, ONTARIO, CANADA Ph: 519-737-1197 Fax: 519-737-1918 TOLL FREE 1877-7412365 Web: metaltanks.com		
TITLE: FMA 40 40usg HYDRAULIC RESERVOIR		
SIZE	DWG. NO.	REV
C		
SCALE: 1:8	WEIGHT:	SHEET 1 OF 1