

**NOTES FOR STANDARD CONSTRUCTION:**  
 ...PRESSURE TESTED @ 5psi.  
 ...INTERIOR FREE OF FOREIGN MATTER.  
 ...FILLER CAP, MAGNETIC DRAIN PLUG PROVIDED.  
 ...STEEL CONSTRUCTION:  
 12ga HRPO BODY, WITH 3/16" HEADS  
 SEMI-GLOSS BLACK ENAMEL APPLIED.  
 ...ALL OPENINGS PLUGGED & INTERIOR FOGGED WITH  
 ANTI-CORROSION OIL PRIOR TO SHIPPING

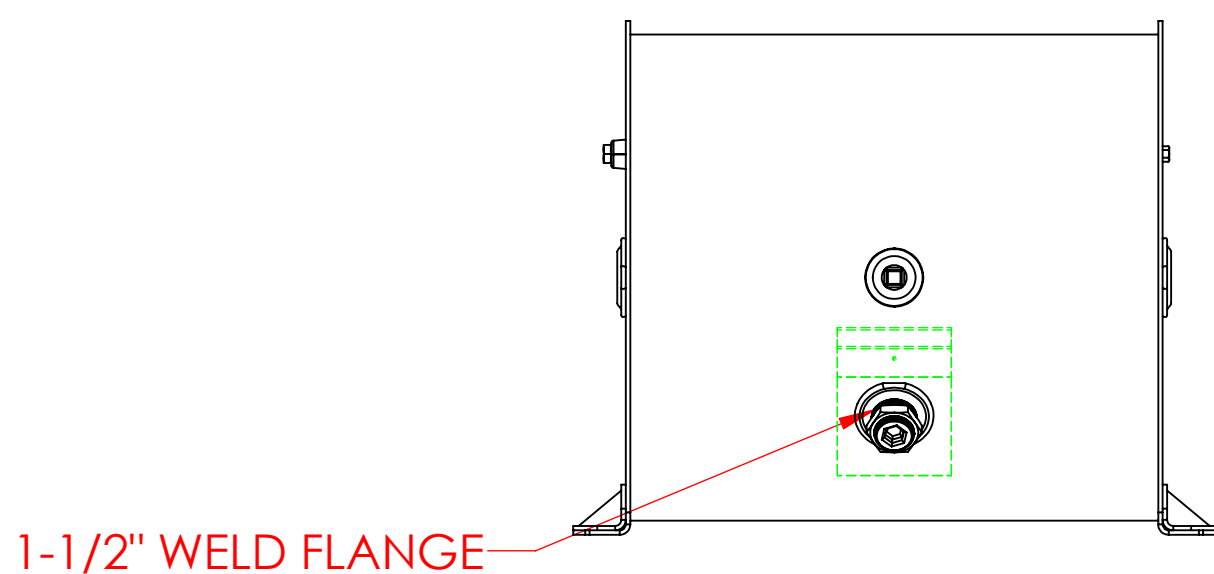
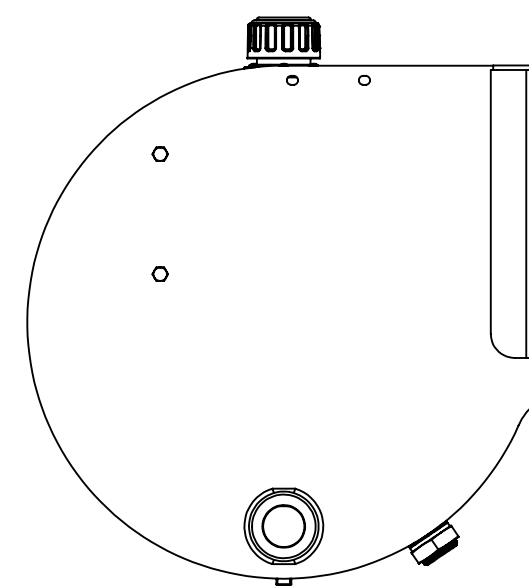
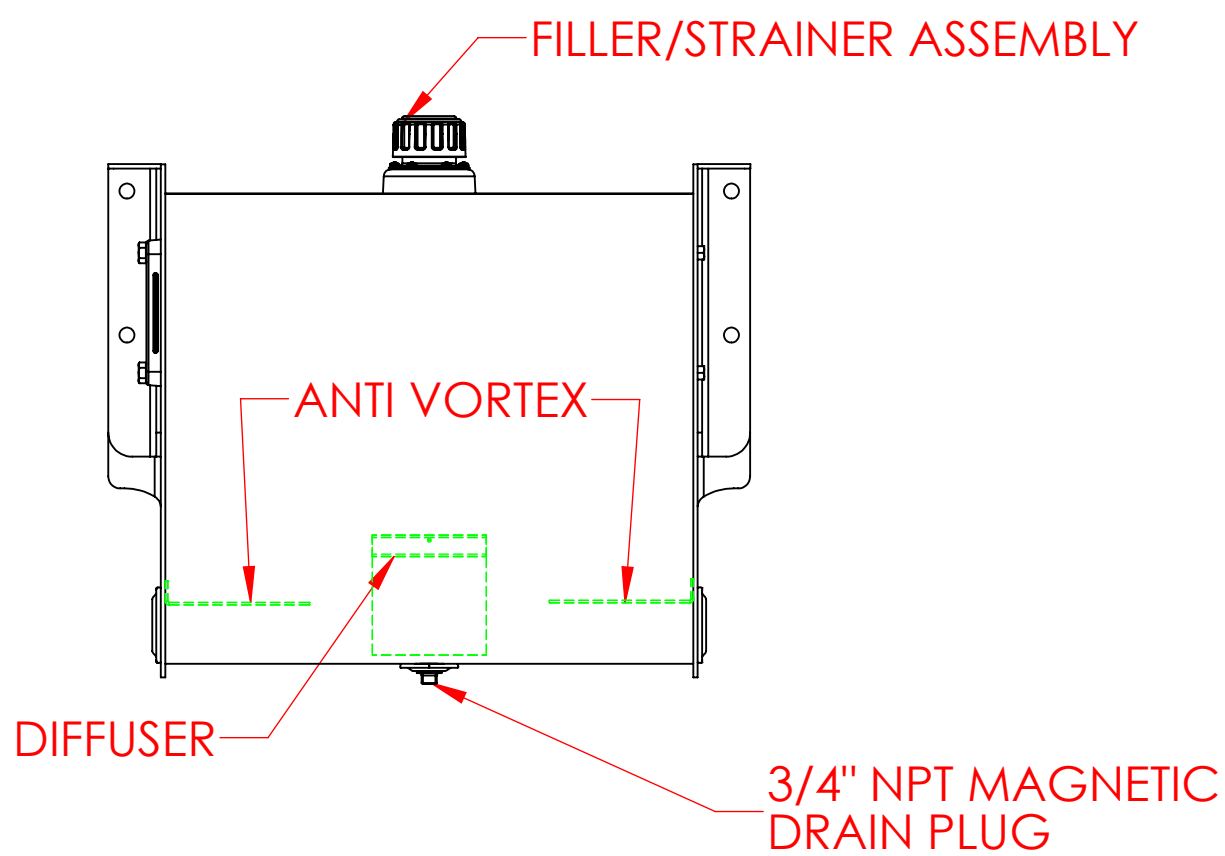
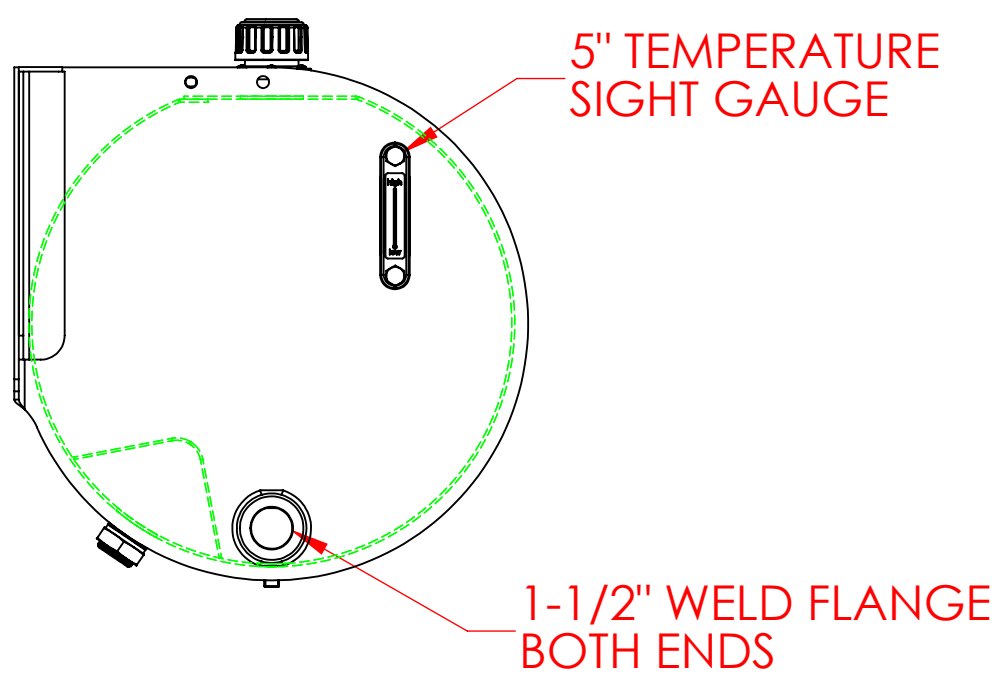

**PROPRIETARY AND CONFIDENTIAL**  
 THE INFORMATION CONTAINED IN THIS  
 DRAWING IS THE SOLE PROPERTY OF  
 PROPOWER MFG. INC. ANY  
 REPRODUCTION IN PART OR AS A WHOLE  
 WITHOUT THE WRITTEN PERMISSION OF  
 PROPOWER MFG. INC. IS PROHIBITED.

UNLESS OTHERWISE SPECIFIED:	DRAWN	NAME	DATE
DIMENSIONS ARE IN INCHES	CHECKED	A.B	08/18/08
TOLERANCES:	ENG APPR.		
FRACTIONAL ±	MFG APPR.		
ANGULAR: MACH ±	Q.A.		
TWO PLACE DECIMAL ±	COMMENTS:		
THREE PLACE DECIMAL ±			
INTERPRET GEOMETRIC TOLERANCING PER:			
MATERIAL	HRPO STEEL		
FINISH			
DO NOT SCALE DRAWING	THIRD ANGLE PROJECTION		

PROPOWER MFG. INC. OLDCASTLE, ONTARIO, CANADA Ph: 519-737-1197 Fax: 519-737-1918 TOLL FREE 1877-7412364 Web: metaltanks.com		
TITLE:		
FMS 30 30usg HYDRAULIC RESERVOIR		
SIZE	DWG. NO.	REV
<b>C</b>	<b>19904</b>	
SCALE: 1:8	WEIGHT: 38lbs.	SHEET 1 OF 2