

ITEM NO.	PART NUMBER	DESCRIPTION	QTY.
1	116-0255	1/8" Aluminum Wrap	1
2	160-0091	18.5X26 Head	2
3	260-0005	1/2" FNPT Aluminum weld flange	2
4	316-0004	2" Aluminum Filler Neck	1
5	458-0100	1/2" NPT Ball Check Drain Plug	1
6	452-0998	2" Thermal Relief Fuel Cap	1
7	217-0002	Top Plate Mount	4
8	217-0003	Top Plate Standoff	2
9	266-0079	GM 6 Hole Float Riser	1
10	266-0080	Float Protector	1
11	312-0010	1" FNPT Aluminum Coupling	1
12	276-0079	GM 6 Hole Float Bolt Adapter	1
13	505-0004	3/8" x 1-1/4" Hex Bolt, Grade 5	6
14	267-0008	Step Insert Assembly	1
15	212-0004	1x1x27 Aluminum Angle	1

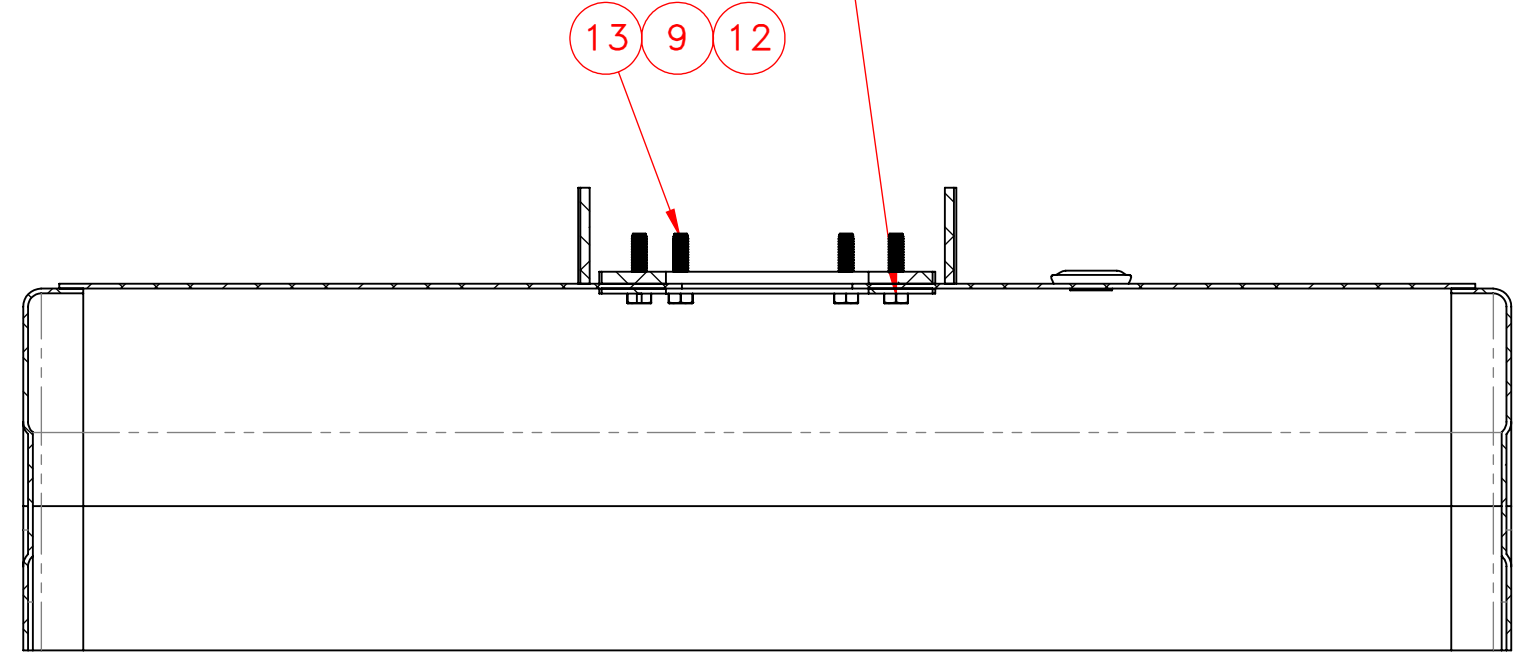
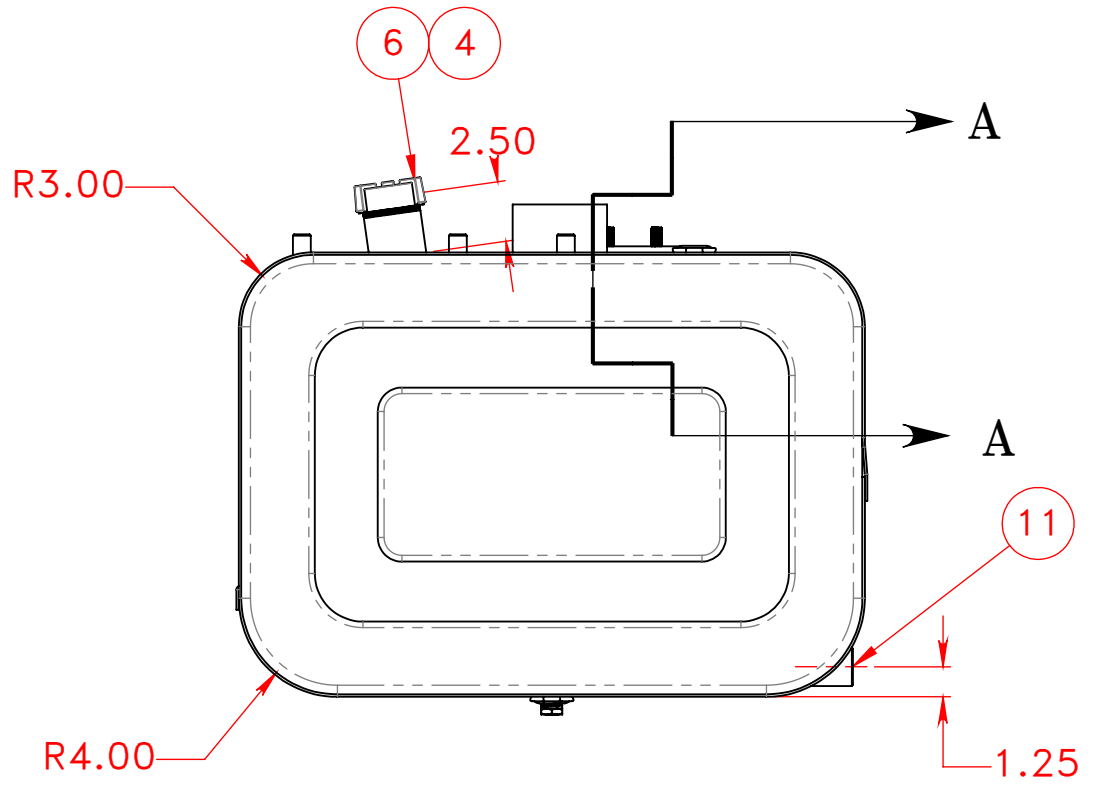
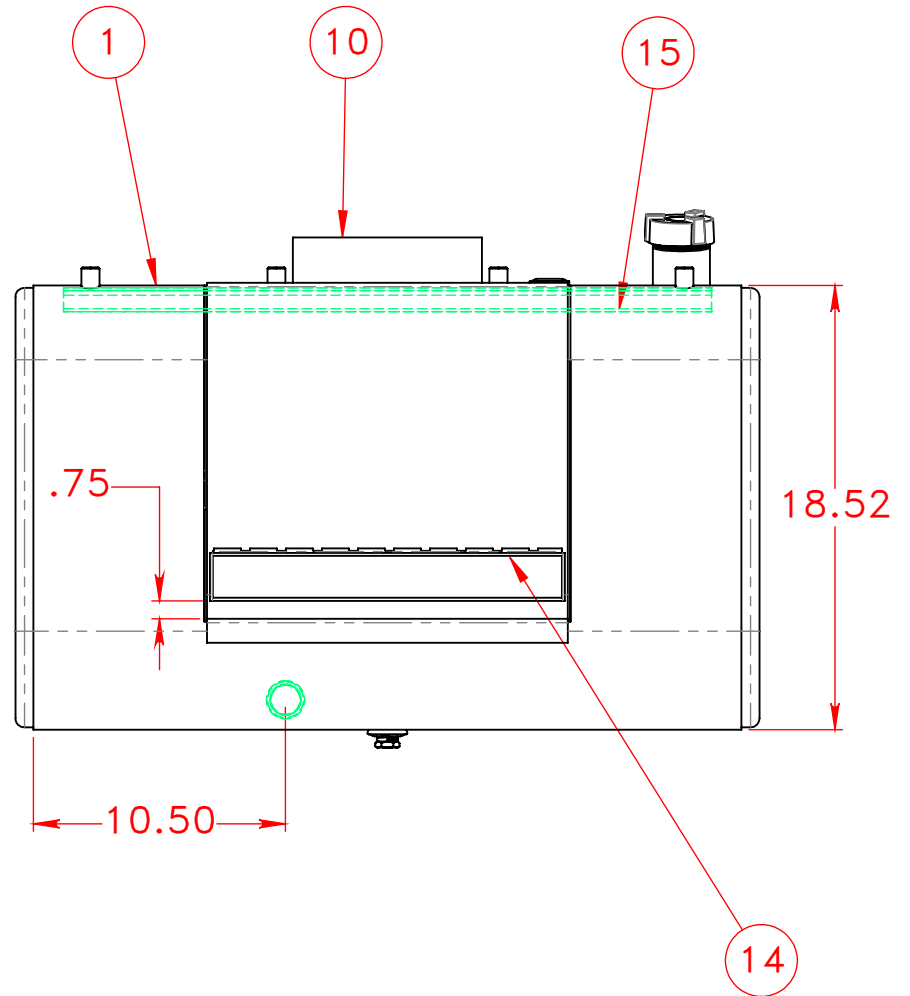
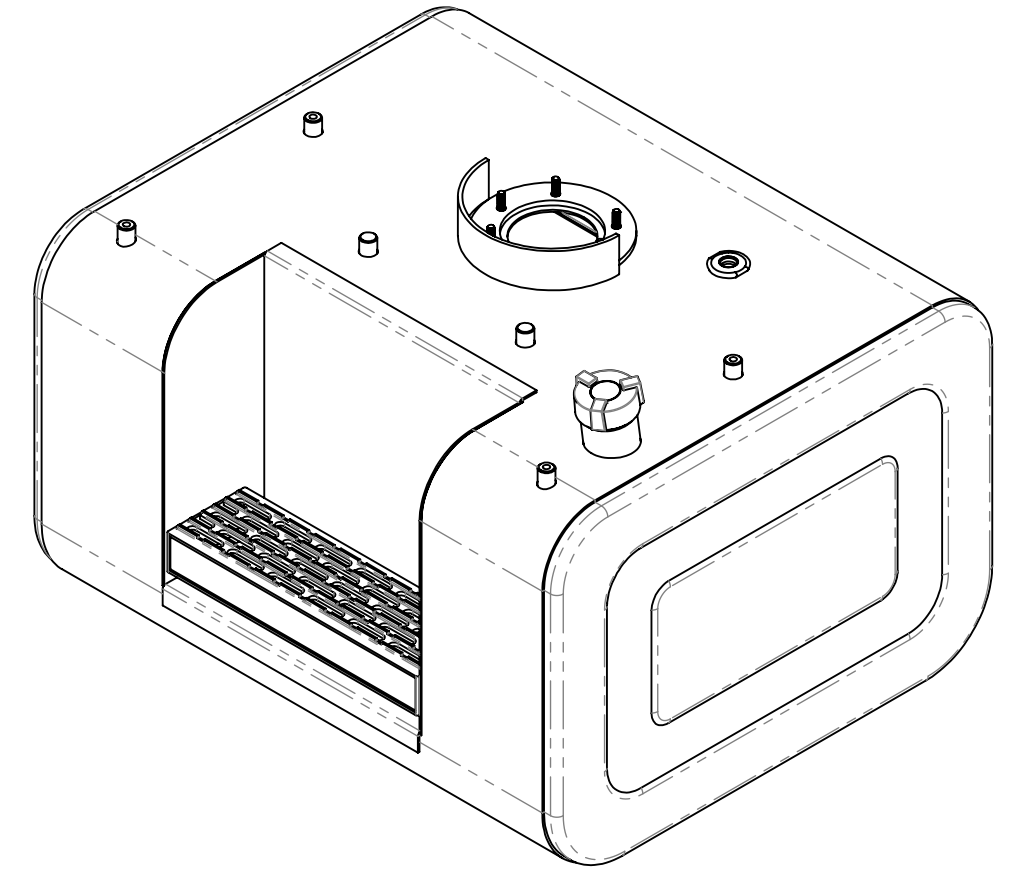

TACK WELD BOLTS TO ADAPTER PLATE
SEAL ADAPTER PLATE TO ALUMINUM RISER
WITH LOCTITE # 518 FLANGE SEALANT

SECTION A-A
SCALE 1 : 4

PROPRIETARY AND CONFIDENTIAL
THE INFORMATION CONTAINED IN THIS DRAWING IS THE SOLE PROPERTY OF PROPOWER MFG. INC. ANY REPRODUCTION IN PART OR AS A WHOLE WITHOUT THE WRITTEN PERMISSION OF PROPOWER MFG. INC. IS PROHIBITED.

UNLESS OTHERWISE SPECIFIED:	DRAWN	NAME	DATE
DIMENSIONS ARE IN INCHES	CHECKED	A.B	11/05/12
TOLERANCES:	ENG APPR.		
FRACTIONAL ± 1/16	MFG APPR.		
ANGULAR: MACH ± 1° BEND ± 1°	Q.A.		
TWO PLACE DECIMAL ± .06	COMMENTS:		
THREE PLACE DECIMAL ± .031			
INTERPRET GEOMETRIC TOLERANCING PER:			
MATERIAL ALUMINUM			
FINISH			
DO NOT SCALE DRAWING	THIRD ANGLE PROJECTION		

PROPOWER MFG. INC.
WINDSOR, ONTARIO, CANADA
Ph: 519-737-1197 Fax: 519-737-1918
TOLL FREE 1-877-741-2365 Web: metaltanks.com

TITLE:
GM-L18-26RFA31
57 US GROSS GALLONS
54 USEBLE GALLONS
DIESEL FUEL TANK

SIZE DWG. NO. REV
C 14467

SCALE: 1:8 WEIGHT: 43 lbs SHEET 1 OF 2