

**DETAIL A
SCALE 1 : 2**

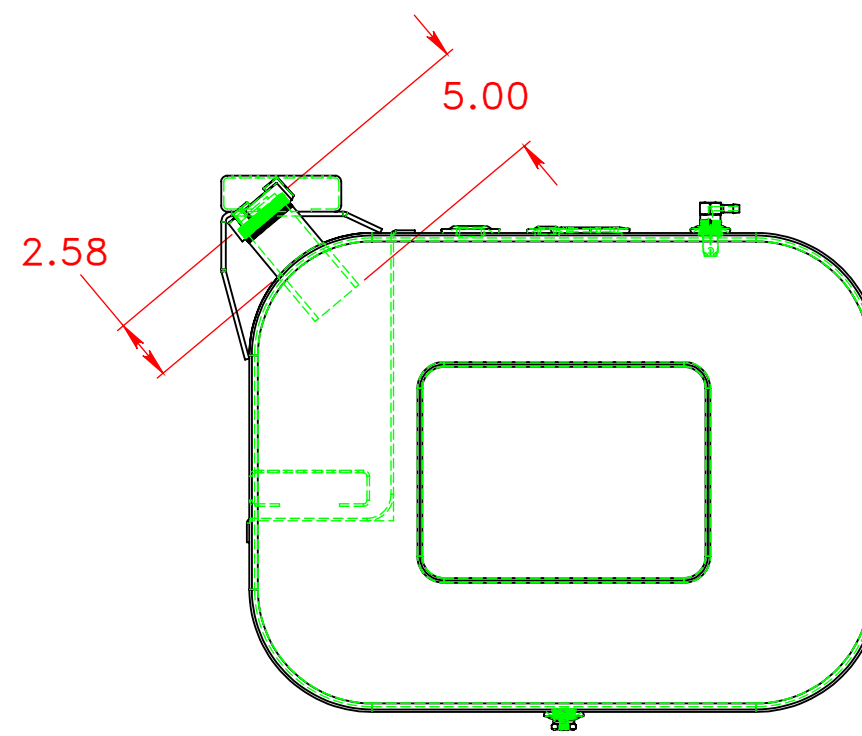
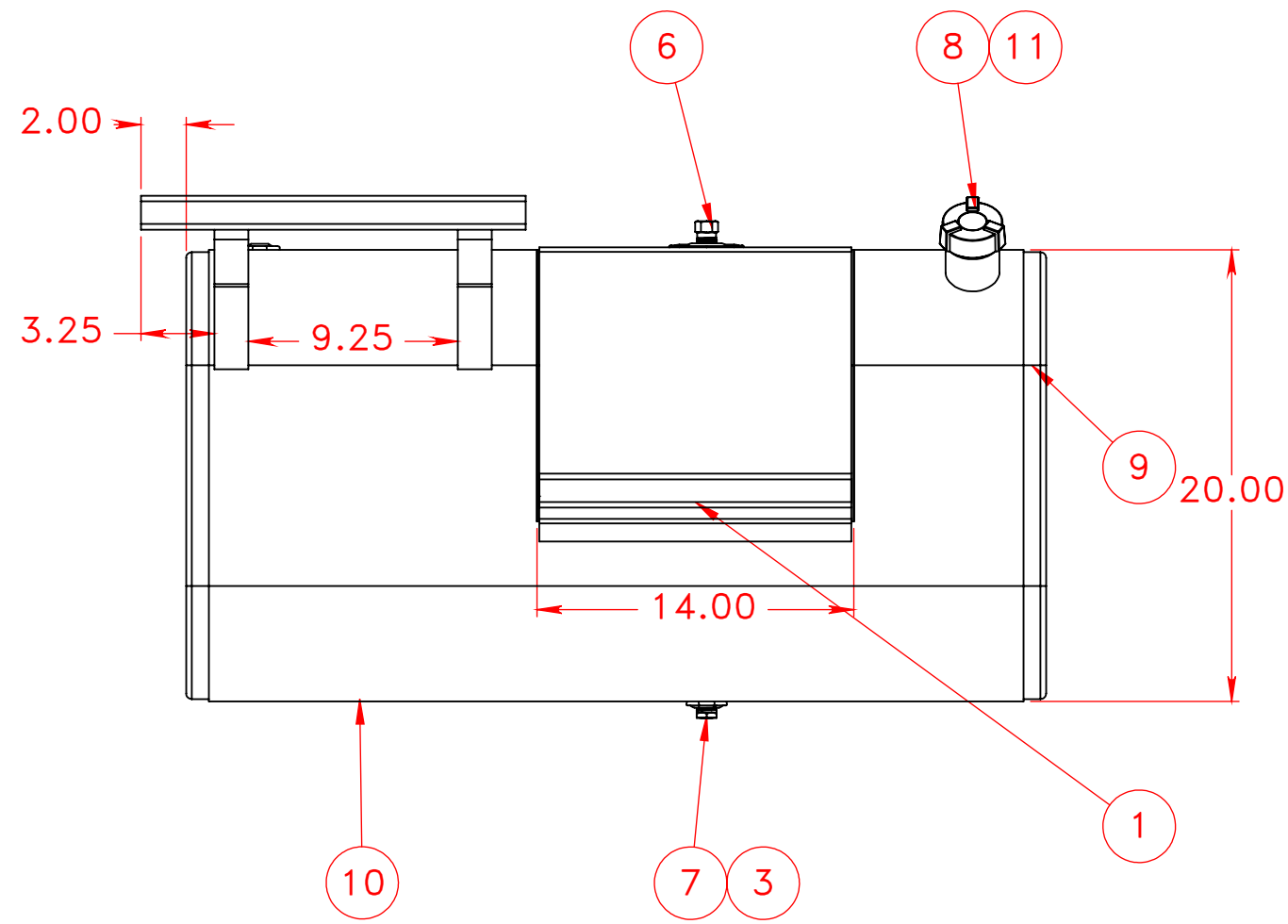
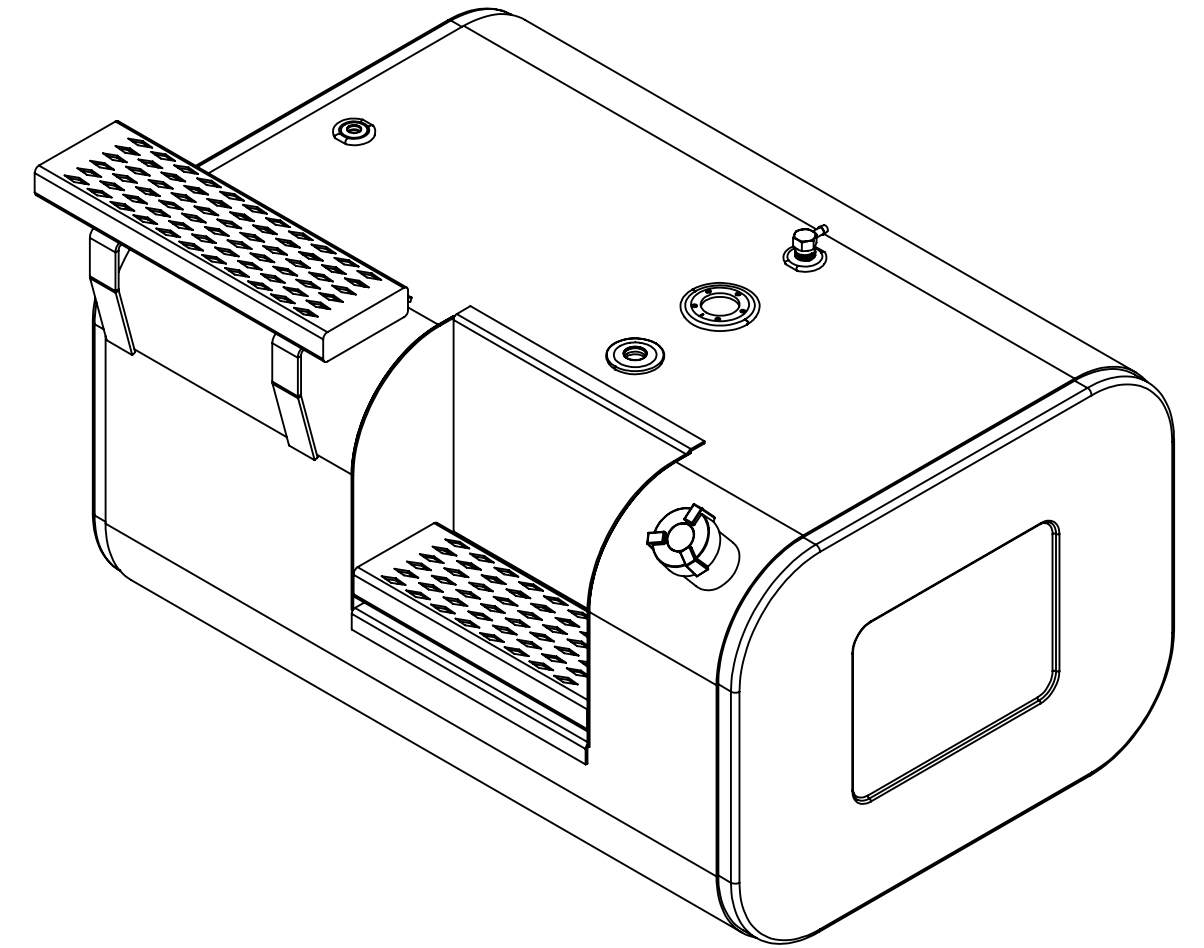

NOTES FOR STANDARD CONSTRUCTION:
 ...MEETS FMCSA REQUIREMENTS.
 ...PRESSURE TESTED @ 5psi PER FHWA
 ...INTERIOR FREE OF FOREIGN MATTER.
 ...FILLER CAP, DRAIN PLUG & VENT PROVIDED.
 ...STEEL CONSTRUCTION 12ga HRPO
 ...STEEL FINISH;
 SEMI-GLOSS BLACK ENAMEL APPLIED.
 ...ALL OPENINGS PLUGGED & THE INTERIOR FOGGED
 WITH ANTI-CORROSION OIL PRIOR TO SHIPPING

ITEM NO.	PART NUMBER	DESCRIPTION	QTY
1	229-0001	Step Extrusion	2
2	270-0010	3/4" FNPT weld flange	1
3	270-0007	1/2" FNPT Steel weld flange	2
4	275-0002	Steel Float Riser	1
5	270-0006	3/8" FNTP weld flange	1
6	454-0937	1/2" NPT Ball Check Vent	1
7	458-0100	1/2" NPT Ball Check Drain Plug	1
8	452-2001	2" Thermal Relief Fuel Cap	1
9	170-0018	20x26 Head	2
10	126-0349	12 ga HRPO Steel Wrap	1
11	316-0005	2" Filler Neck 5" Long	1

UNLESS OTHERWISE SPECIFIED: DIMENSIONS ARE IN INCHES TOLERANCES: FRACTIONAL ± ANGULAR: MACH ± BEND ± TWO PLACE DECIMAL ± THREE PLACE DECIMAL ±	DRAWN	NAME	DATE	PROPOWER MFG. INC. WINDSOR, ONTARIO, CANADA Ph: 519-737-1197 Fax: 519-737-1918 TOLL FREE 1-877-741-2364 Web: metaltanks.com TITLE: IN-L20-26RF2S38 75 US GROSS GALLONS 71 USABLE GALLONS DIESEL FUEL TANK SIZE DWG. NO. C 10061 SCALE: 1:8 WEIGHT: 145 LBS SHEET 1 OF 2
	CHECKED	Admin	07-21-08	
	ENG APPR.			
	MFG APPR.			
INTERPRET GEOMETRIC TOLERANCING PER:	COMMENTS:			
MATERIAL	STEEL			
FINISH	THIRD ANGLE PROJECTION			
DO NOT SCALE DRAWING				