

DETAIL A
SCALE 1 : 4

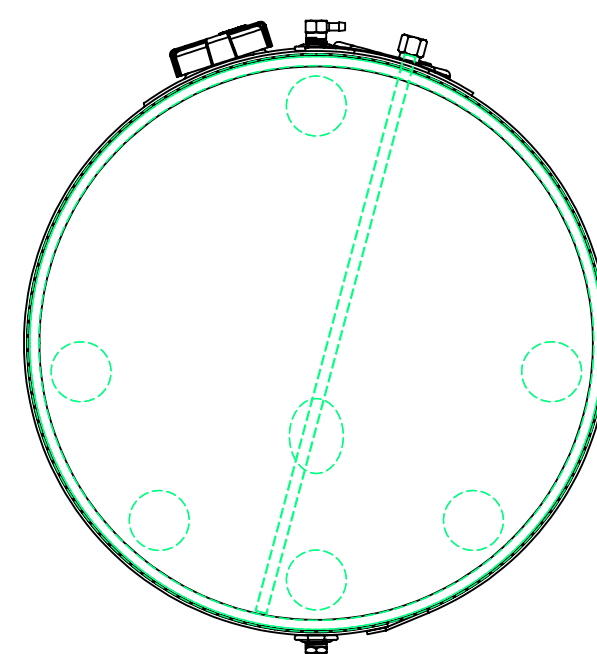
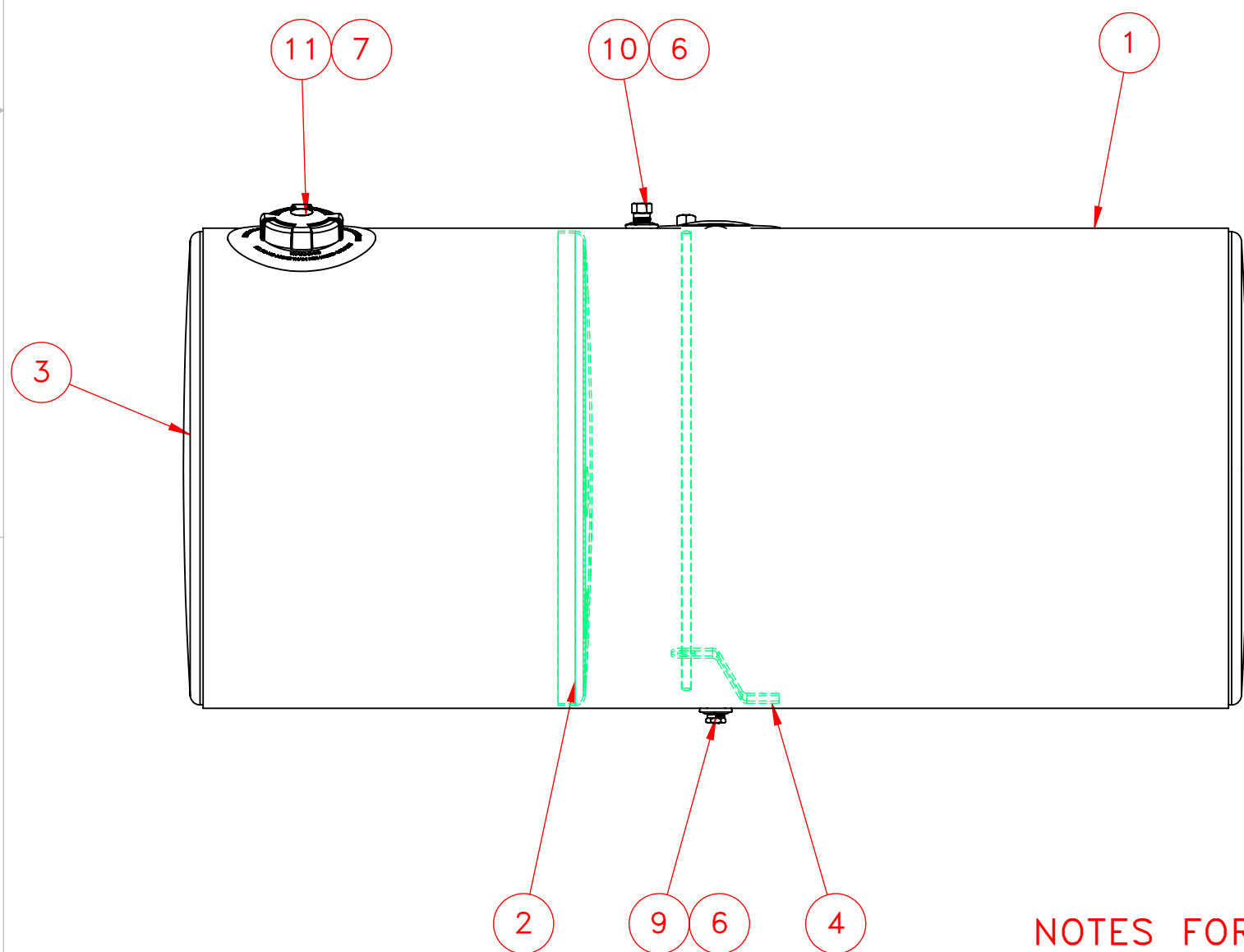

NOTES FOR STANDARD CONSTRUCTION:
 ...MEETS FMCSA REQUIREMENTS.
 ...PRESSURE TESTED @ 5psi
 ...INTERIOR FREE OF FOREIGN MATTER.
 ...FILLER CAP, DRAIN PLUG & VENT PROVIDED.
 ...ALUMINUM CONSTRUCTION:
 5052-H32 ALUMINUM, BRIGHT FINISH
 HEADS ARE 0.100" & SHELL IS 0.125"
 ...ALL OPENINGS PLUGGED PRIOR TO SHIPPING

ITEM NO.	PART NUMBER	DESCRIPTION	QTY.
1	116-1399	1/8" Auminum Wrap	1
2	162-0054	24" Baffle	1
3	160-0054	24" Head 0.100" Aluminum	2
4	490-3001	Down Tube Support	1
5	260-0733	Float/Draw/Return Plate	1
6	260-0005	1/2" FNPT Aluminum weld flange	2
7	316-0094	Filler 3" Pocket Flange	1
8	368-0005	1/4" NPT Brass Drain Plug Hex	1
9	458-0100	1/2" NPT Ball Check Drain Plug	1
10	454-0937	1/2" NPT Ball Check Vent	1
11	452-1628	Fuel Cap 3" Pressure Relief	1
12	490-0024-Z	1/2" NPT Down Tube	1

<small>PROPRIETARY AND CONFIDENTIAL</small> <small>THE INFORMATION CONTAINED IN THIS DRAWING IS THE SOLE PROPERTY OF PROPOWER MFG. INC. ANY REPRODUCTION IN PART OR AS A WHOLE WITHOUT THE WRITTEN PERMISSION OF PROPOWER MFG. INC. IS PROHIBITED.</small>	UNLESS OTHERWISE SPECIFIED:	DRAWN	NAME	DATE	PROPOWER MFG. INC. <small>WINDSOR, ONTARIO, CANADA</small> <small>Ph: 519-737-1197 Fax: 519-737-1918</small> <small>TOLL FREE 1-877-741-2365 Web: metaltanks.com</small>
	DIMENSIONS ARE IN INCHES	CHECKED	A.B	11/13/20	
	TOLERANCES:	ENG APPR.			
	FRACTIONAL ± 1/16 ANGULAR: MACH ± 1° BEND ± 1° TWO PLACE DECIMAL ± .06 THREE PLACE DECIMAL ± .031	MFG APPR.			
	INTERPRET GEOMETRIC TOLERANCING PER:	COMMENTS:			TITLE:
	MATERIAL				KW-L24CFA54-D
	FINISH				100 US gal DIESEL FUEL TANK
	DO NOT SCALE DRAWING	THIRD ANGLE PROJECTION			SIZE DWG. NO. REV
					C 26854
					SCALE: 1:8 WEIGHT: 76 LBS SHEET 1 OF 1