

**DETAIL A**  
**SCALE 1 : 4**

**NOTES FOR STANDARD CONSTRUCTION:**  
 ...MEETS FMCSA REQUIREMENTS.  
 ...PRESSURE TESTED @ 5psi  
 ...INTERIOR FREE OF FOREIGN MATTER.  
 ...FILLER CAP, DRAIN PLUG,  
 DRAW TUBE & VENT PROVIDED.  
 ...FULL BAFFLE(S) WHERE SHOWN  
 ...ALUMINUM CONSTRUCTION:  
 5052-H32 ALUMINUM, BRIGHT FINISH  
 HEADS ARE 0.100" & SHELL IS 0.125"  
 ...ALL OPENINGS PLUGGED PRIOR TO SHIPPING

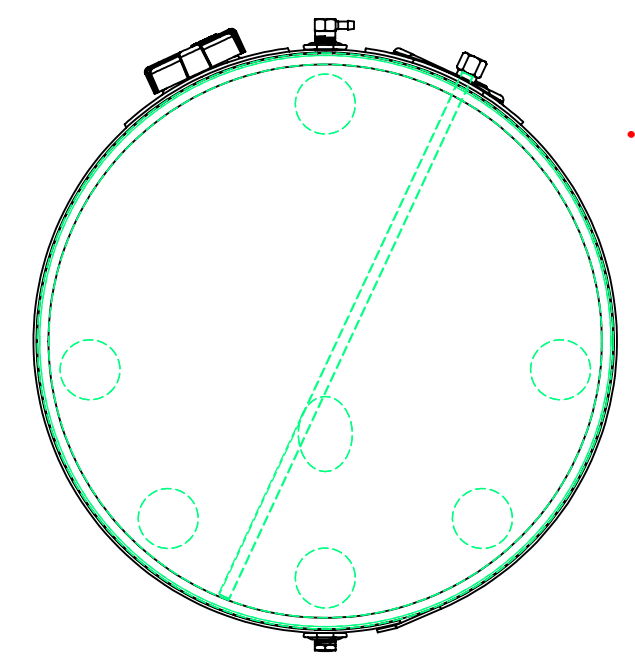
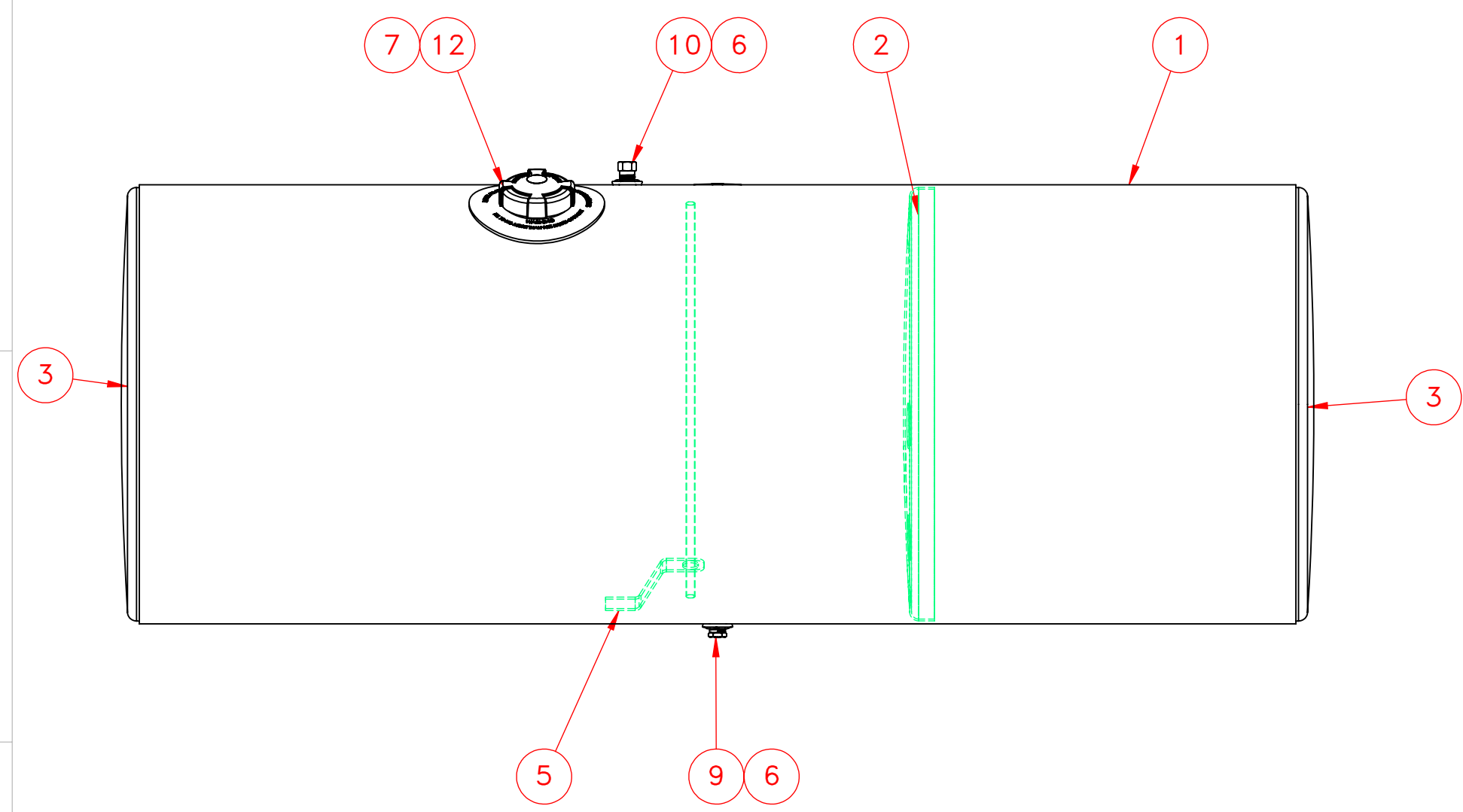

**PROPRIETARY AND CONFIDENTIAL**  
 THE INFORMATION CONTAINED IN THIS DRAWING IS THE SOLE PROPERTY OF PROPOWER MFG. INC. ANY REPRODUCTION IN PART OR AS A WHOLE WITHOUT THE WRITTEN PERMISSION OF PROPOWER MFG. INC. IS PROHIBITED.

UNLESS OTHERWISE SPECIFIED:	DRAWN	NAME	DATE
DIMENSIONS ARE IN INCHES	CHECKED	A.B	06/22/21
TOLERANCES:	ENG APPR.		
FRACTIONAL ± 1/16	MFG APPR.		
ANGULAR: MACH ± 1° BEND ± 1°	Q.A.		
TWO PLACE DECIMAL ± .06	COMMENTS:		
THREE PLACE DECIMAL ± .031			
INTERPRET GEOMETRIC TOLERANCING PER:			
MATERIAL	ALUMINUM		
FINISH			
DO NOT SCALE DRAWING	THIRD ANGLE PROJECTION		

PROPOWER MFG. INC. WINDSOR, ONTARIO, CANADA Ph: 519-737-1197 Fax: 519-737-1918 TOLL FREE 1-877-741-2365 Web: metaltanks.com		
<b>TITLE:</b> KW-L24CFA66-F 129 US GROSS GALLONS 122 USABLE GALLONS DIESEL FUEL TANK		
<b>SIZE</b> DWG. NO. <b>C</b> <b>27667</b>	REV	SCALE: 1:8 WEIGHT: 79 LBS SHEET 1 OF 2

ITEM NO.	PART NUMBER	MakeOrBuy	DESCRIPTION	QTY.
1	116-1506		1/8" Aluminium Wrap	1
2	162-0054		24" Baffle	1
3	160-0054		24" Aluminum Head	2
4	260-0733	\$	Float/Draw/Return Plate	1
5	490-3001		Down Tube Support	1
6	260-0005	\$	1/2" FNPT Aluminum weld flange	2
7	316-0094	\$	Filler 3" Pocket Flange	1
8	368-0005	\$	1/4" NPT Brass Drain Plug Hex	1
9	458-0100	\$	1/2" NPT Ball Check Drain Plug	1
10	454-0937	\$	1/2" NPT Ball Check Vent	1
11	490-0024-Z		1/2" NPT Down Tube	1
12	452-1628	\$	Fuel Cap 3" Pressure Relief	1

**PROPRIETARY AND CONFIDENTIAL**  
 THE INFORMATION CONTAINED IN THIS  
 DRAWING IS THE SOLE PROPERTY OF  
 PROPOWER MFG. INC. ANY  
 REPRODUCTION IN PART OR AS A WHOLE  
 WITHOUT THE WRITTEN PERMISSION OF  
 PROPOWER MFG. INC. IS PROHIBITED.

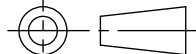
UNLESS OTHERWISE SPECIFIED:		NAME	DATE	<b>PROPOWER MFG. INC.</b> WINDSOR, ONTARIO, CANADA Ph; 519-737-1197 Fax; 519-737-1918 TOLL FREE 1877-7412365 Web; metaltanks.com	
DIMENSIONS ARE IN INCHES		DRAWN	A.B		06/22/21
TOLERANCES:		CHECKED			
FRACTIONAL ± 1/16		ENG APPR.			
ANGULAR: MACH ± 1° BEND ± 1°		MFG APPR.			
TWO PLACE DECIMAL ± .06		Q.A.			
THREE PLACE DECIMAL ± .031		COMMENTS:			
INTERPRET GEOMETRIC TOLERANCING PER:					
MATERIAL					
FINISH					
DO NOT SCALE DRAWING		THIRD ANGLE PROJECTION 			
TITLE:		<b>BOM</b>			
SIZE	DWG. NO.	REV			
<b>B</b>					
SCALE: 1:8	WEIGHT:	SHEET 2 OF 2			