

DETAIL A  
SCALE 1 : 2

NOTES FOR STANDARD CONSTRUCTION:

- ...PRESSURE TESTED @ 5psi PER FMCSA
- ...INTERIOR FREE OF FOREIGN MATTER.
- ...FILLER CAP, DRAIN PLUG, DRAW TUB & VENT PROVIDED.
- ...STEEL CONSTRUCTION 12ga HRPO
- ...STEEL FINISH;
- SEMI-GLOSS BLACK ENAMEL APPLIED.
- ...ALL OPENINGS PLUGGED & THE INTERIOR FOGGED WITH ANTI-CORROSION OIL PRIOR TO SHIPPING

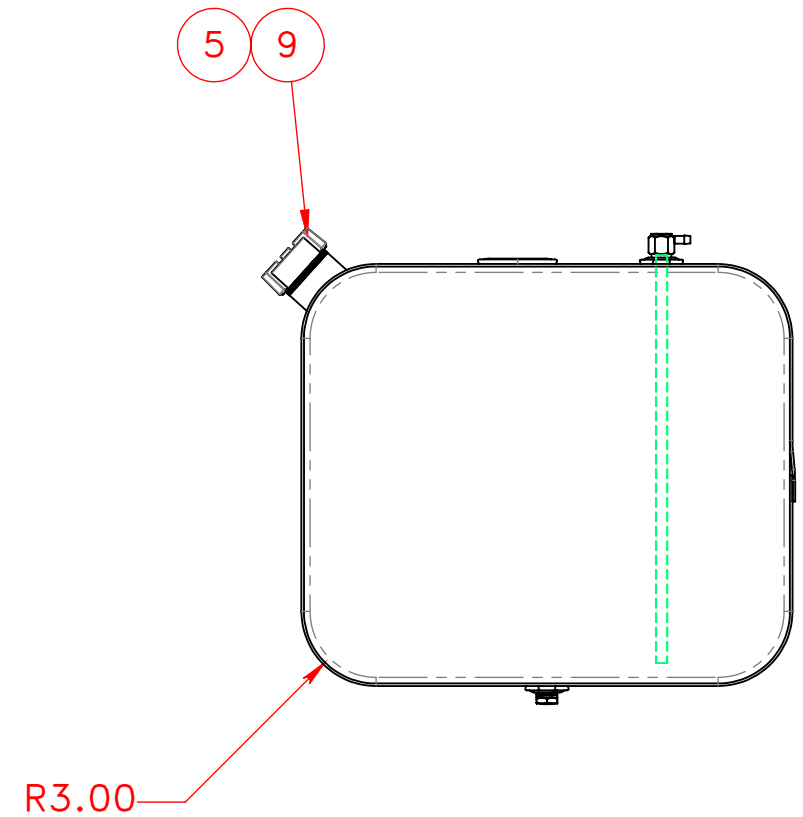
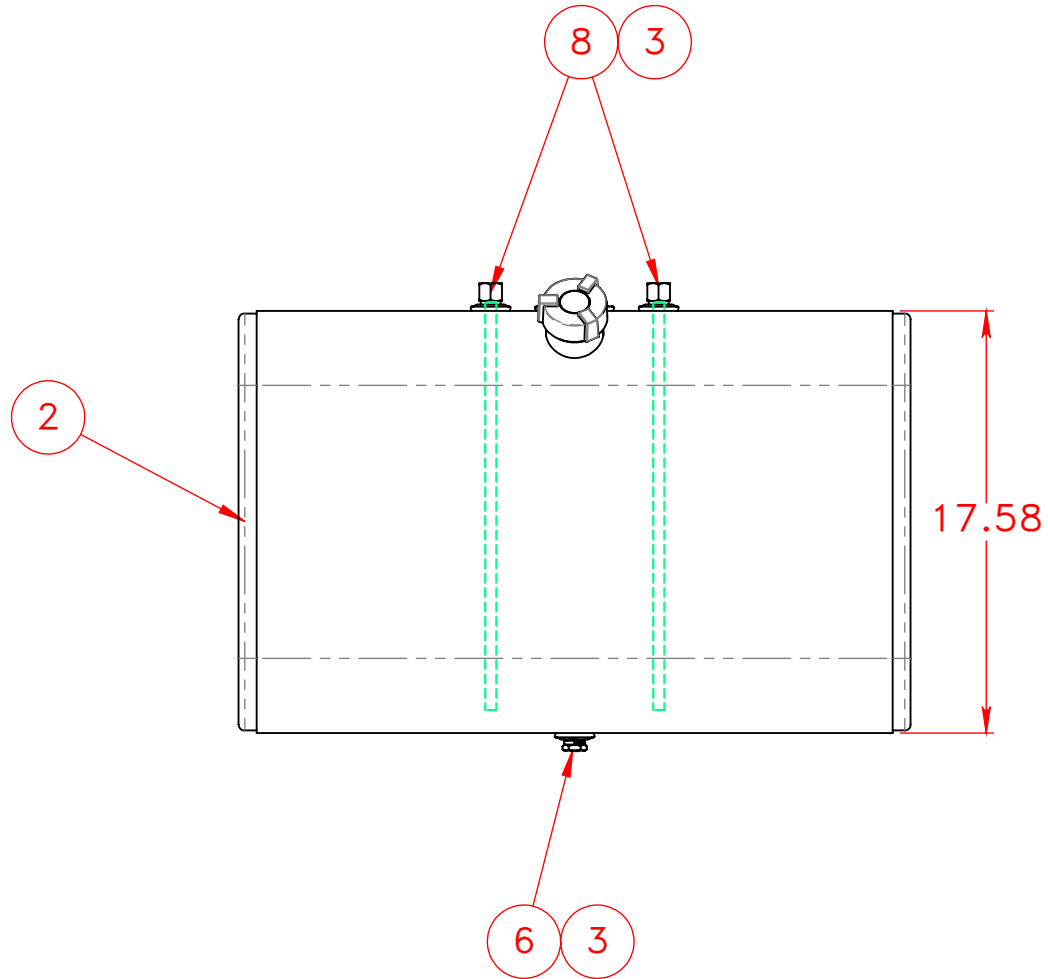

ITEM NO.	PART NUMBER	DESCRIPTION	QTY.
1	126-0237	12 ga HRPO Steel Wrap	1
2	170-0015	17x20 Head	2
3	270-0007	1/2" FNPT Steel weld flange	4
4	275-0002	Steel Float Riser	1
5	326-0001	2" Steel Filler Neck	1
6	458-0100	1/2" NPT Ball Check Drain Plug	1
7	454-0937	1/2" NPT Ball Check Vent	1
8	490-0017-Z	1/2" NPT Down Tube	2
9	452-0998	2" Thermal Relief Fuel Cap	1

UNLESS OTHERWISE SPECIFIED: DIMENSIONS ARE IN INCHES TOLERANCES: FRACTIONAL: ± 1/16 ANGULAR: MACH ± 1° BEND ± 1° TWO PLACE DECIMAL ± .06 THREE PLACE DECIMAL ± .031	DRAWN	NAME	DATE	PROPOWER MFG. INC. OLDCASTLE, ONTARIO, CANADA Ph: 519-737-1197 Fax: 519-737-1918 TOLL FREE 1877-7412365 Web: metaltanks.com
	CHECKED	A.B	05/01/15	
INTERPRET GEOMETRIC TOLERANCING PER: MATERIAL HRPO STEEL	ENG APPR.			TITLE: 17-20RF28K 41 usg DIESEL FUEL TANK
	MFG APPR.			
FINISH DO NOT SCALE DRAWING	Q.A.			SIZE DWG. NO. <b>C 18568</b>
	THIRD ANGLE PROJECTION			REV SCALE: 1:8 WEIGHT: SHEET 1 OF 2

PROPRIETARY AND CONFIDENTIAL  
 THE INFORMATION CONTAINED IN THIS DRAWING IS THE SOLE PROPERTY OF PROPOWER MFG. INC. ANY REPRODUCTION IN PART OR AS A WHOLE WITHOUT THE WRITTEN PERMISSION OF PROPOWER MFG. INC. IS PROHIBITED.