

**DETAIL A**  
**SCALE 1 : 2**

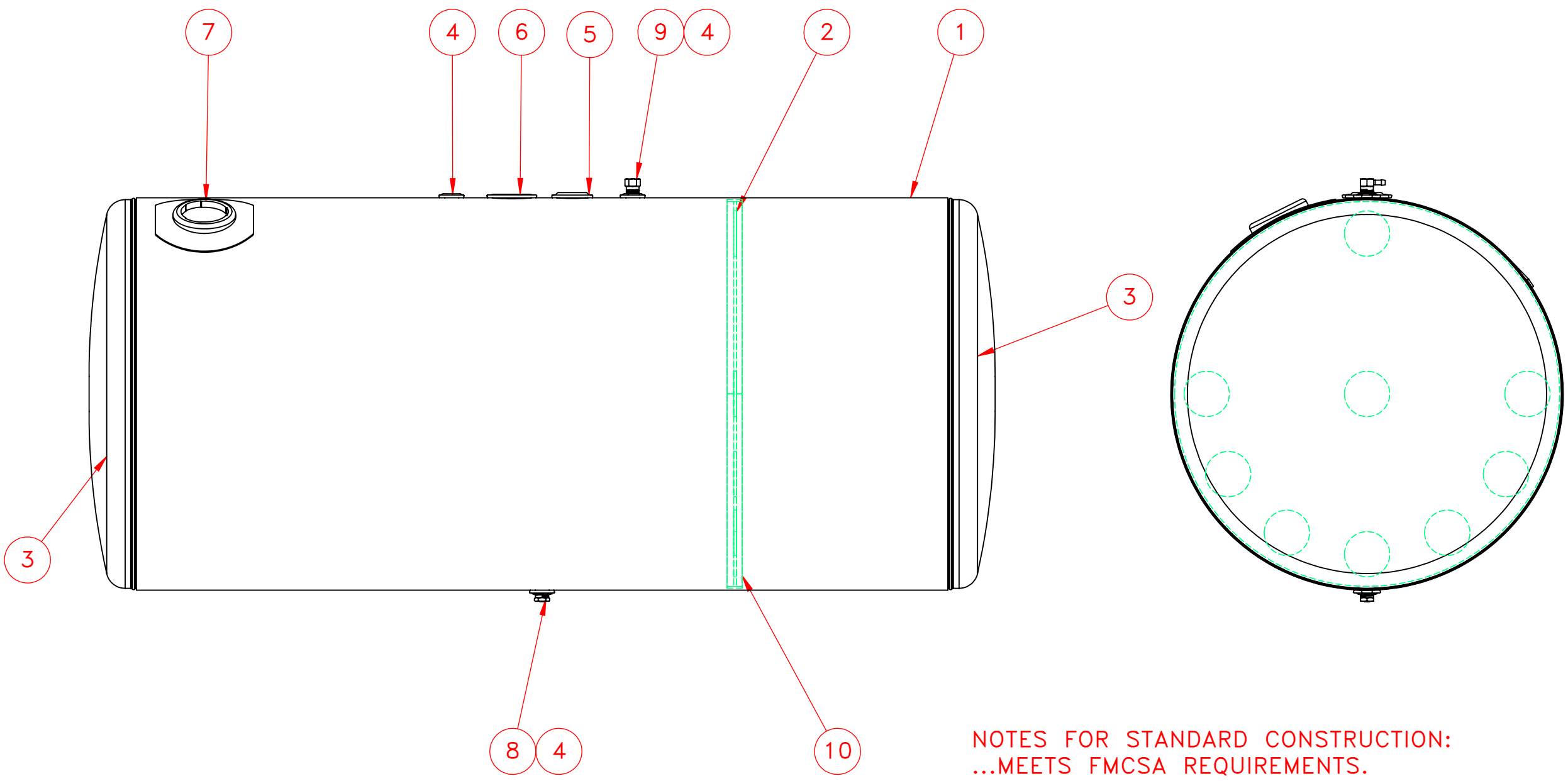
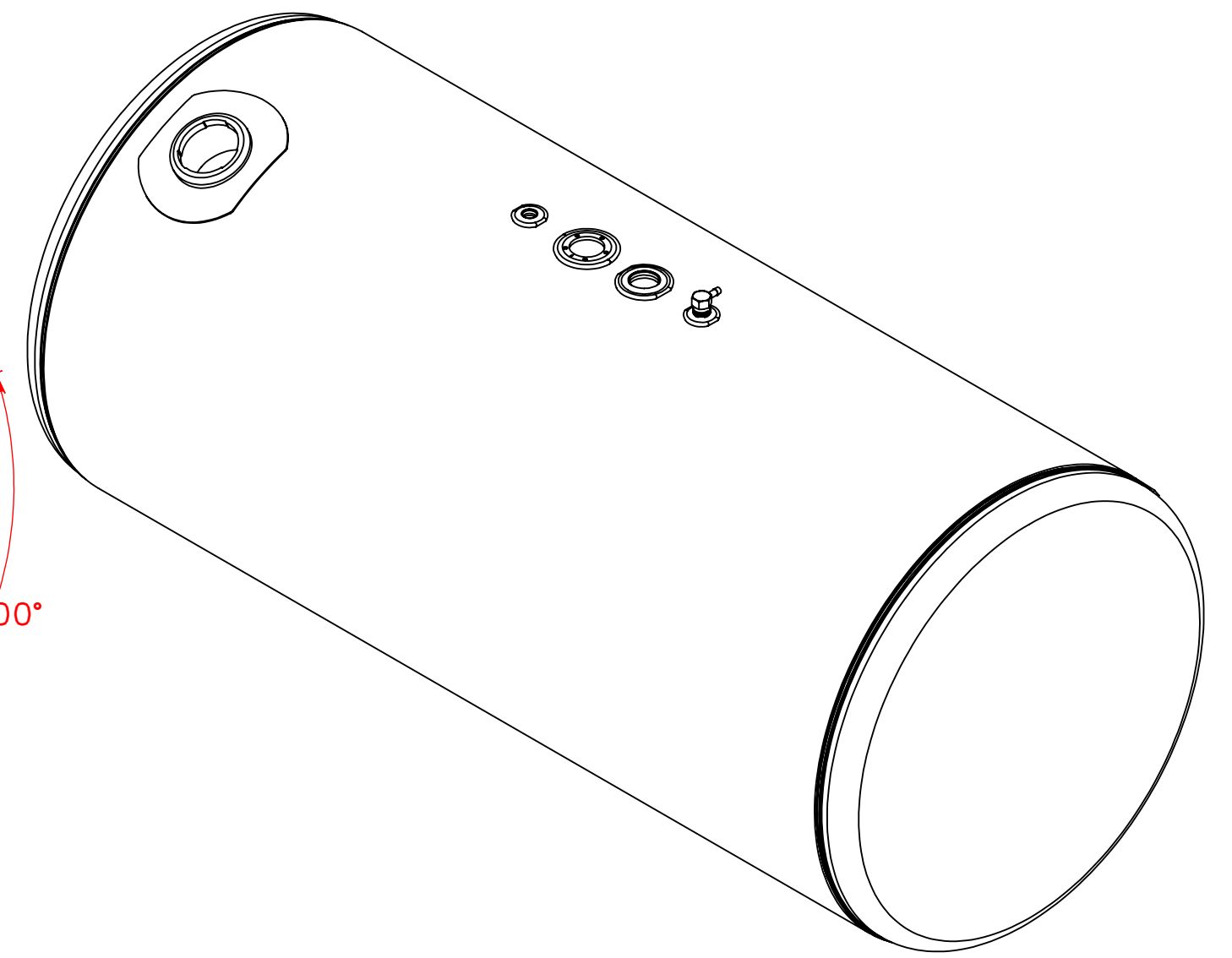

ITEM NO.	PART NUMBER	DESCRIPTION	QTY.
1	116-0594	1/8" Auminum Wrap	1
2	262-0076	26" Peterbilt Baffle	1
3	160-0109	26" Aluminum Head	2
4	260-0005	1/2" FNPT Aluminum weld flange	3
5	260-0008	1 1/4" FNPT weld flange	1
6	265-0009	Aluminum Float Riser	1
7	316-0016	Peaterbilt Filer	1
8	458-0100	1/2" NPT Ball Check Drain Plug	1
9	454-0937	1/2" NPT Ball Check Vent	1
10	260-0104	Baffle Ring	1

**NOTES FOR STANDARD CONSTRUCTION:**  
 ...MEETS FMCSA REQUIREMENTS.  
 ...PRESSURE TESTED @ 5psi  
 ...INTERIOR FREE OF FOREIGN MATTER.  
 ...DRAIN PLUG & VENT PROVIDED.  
 ...FULL BAFFLE(S) WHERE SHOWN  
 ...ALUMINUM CONSTRUCTION:  
 5052-H32 ALUMINUM, BRIGHT FINISH  
 HEADS ARE 0.100" & SHELL IS 0.125"  
 ...ALL OPENINGS PLUGGED PRIOR TO SHIPPING

<small>UNLESS OTHERWISE SPECIFIED:</small> <small>DIMENSIONS ARE IN INCHES</small> <small>TOLERANCES:</small> <small>FRACTIONAL ± 1/16</small> <small>ANGULAR: MACH ± 1° BEND ± 1°</small> <small>TWO PLACE DECIMAL ± .06</small> <small>THREE PLACE DECIMAL ± .031</small>	<small>DRAWN</small> <small>CHECKED</small> <small>ENG APPR.</small> <small>MFG APPR.</small> <small>Q.A.</small>	<small>NAME</small> <small>DATE</small>	<b>PROPOWER MFG. INC.</b> <small>WINDSOR, ONTARIO, CANADA</small> <small>Ph: 519-737-1197 Fax: 519-737-1918</small> <small>TOLL FREE 1-877-741-2365 Web: metaltanks.com</small> <b>TITLE:</b> <b>PB-R26CFA60-D</b> <b>135usg DIESEL FUEL TANK</b>	
	<small>INTERPRET GEOMETRIC TOLERANCING PER:</small> <small>MATERIAL</small> <b>ALUMINUM</b>	<small>COMMENTS:</small>		<small>SIZE DWG. NO.</small> <b>C 23699</b>
	<small>FINISH</small> <small>DO NOT SCALE DRAWING</small>	<small>THIRD ANGLE PROJECTION</small>		<small>SCALE: 1:8</small> <small>WEIGHT: 82 LBS</small> <small>SHEET 1 OF 2</small>
	<small>PROPRIETARY AND CONFIDENTIAL</small> <small>THE INFORMATION CONTAINED IN THIS DRAWING IS THE SOLE PROPERTY OF PROPOWER MFG. INC. ANY REPRODUCTION IN PART OR AS A WHOLE WITHOUT THE WRITTEN PERMISSION OF PROPOWER MFG. INC. IS PROHIBITED.</small>	<small>DATE</small> <small>05-09-18</small>		<small>REV</small>