

DETAIL A
SCALE 1 : 2

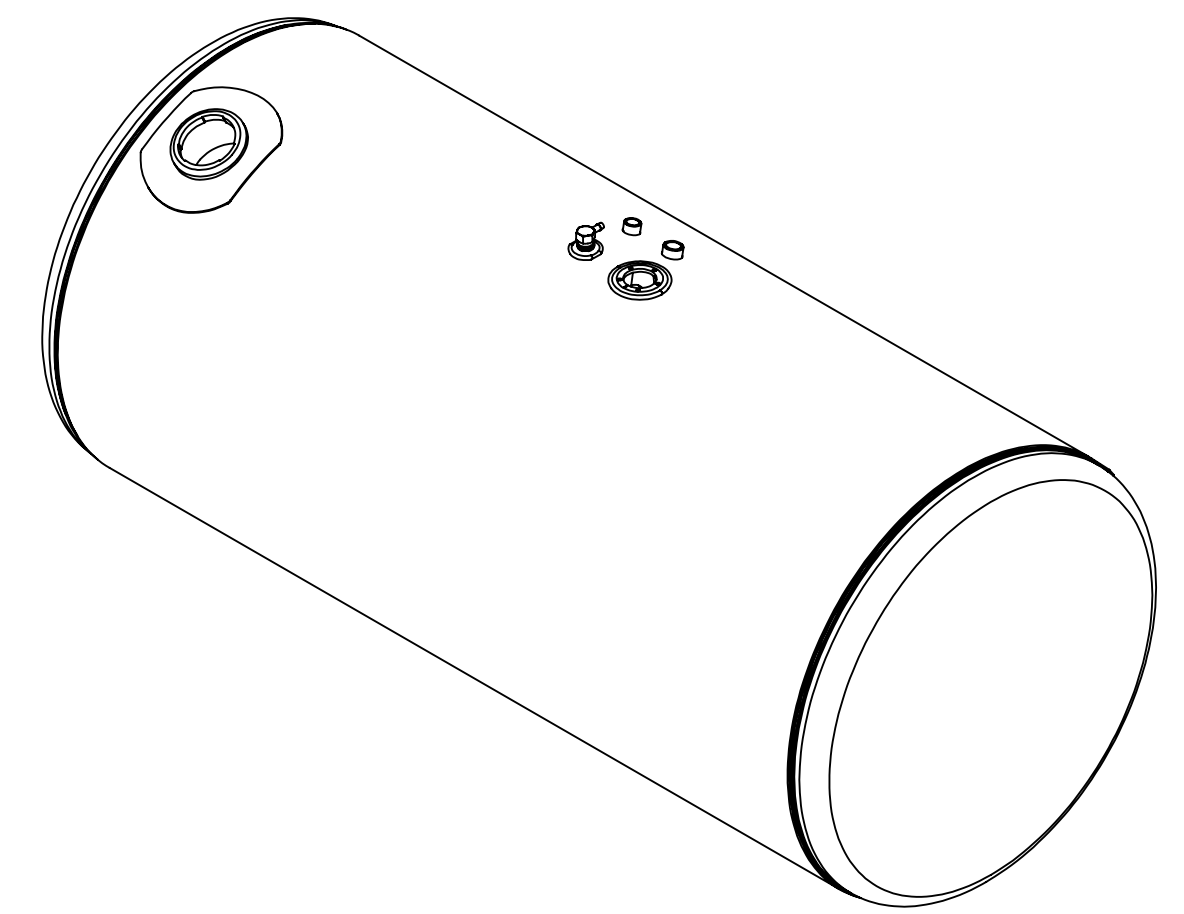

NOTES FOR STANDARD CONSTRUCTION:
 ...MEETS FMCSA REQUIREMENTS.
 ...PRESSURE TESTED @ 5psi
 ...INTERIOR FREE OF FOREIGN MATTER.
 ...DRAIN PLUG & VENT PROVIDED.
 ...FULL BAFFLE(S) WHERE SHOWN
 ...ALUMINUM CONSTRUCTION:
 1/8" 5052-H32 ALUMINUM, BRIGHT FINISH.
 ...ALL OPENINGS PLUGGED PRIOR TO SHIPPING

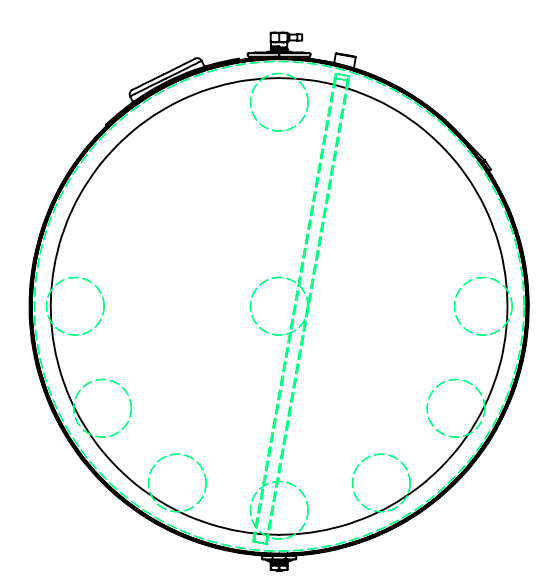
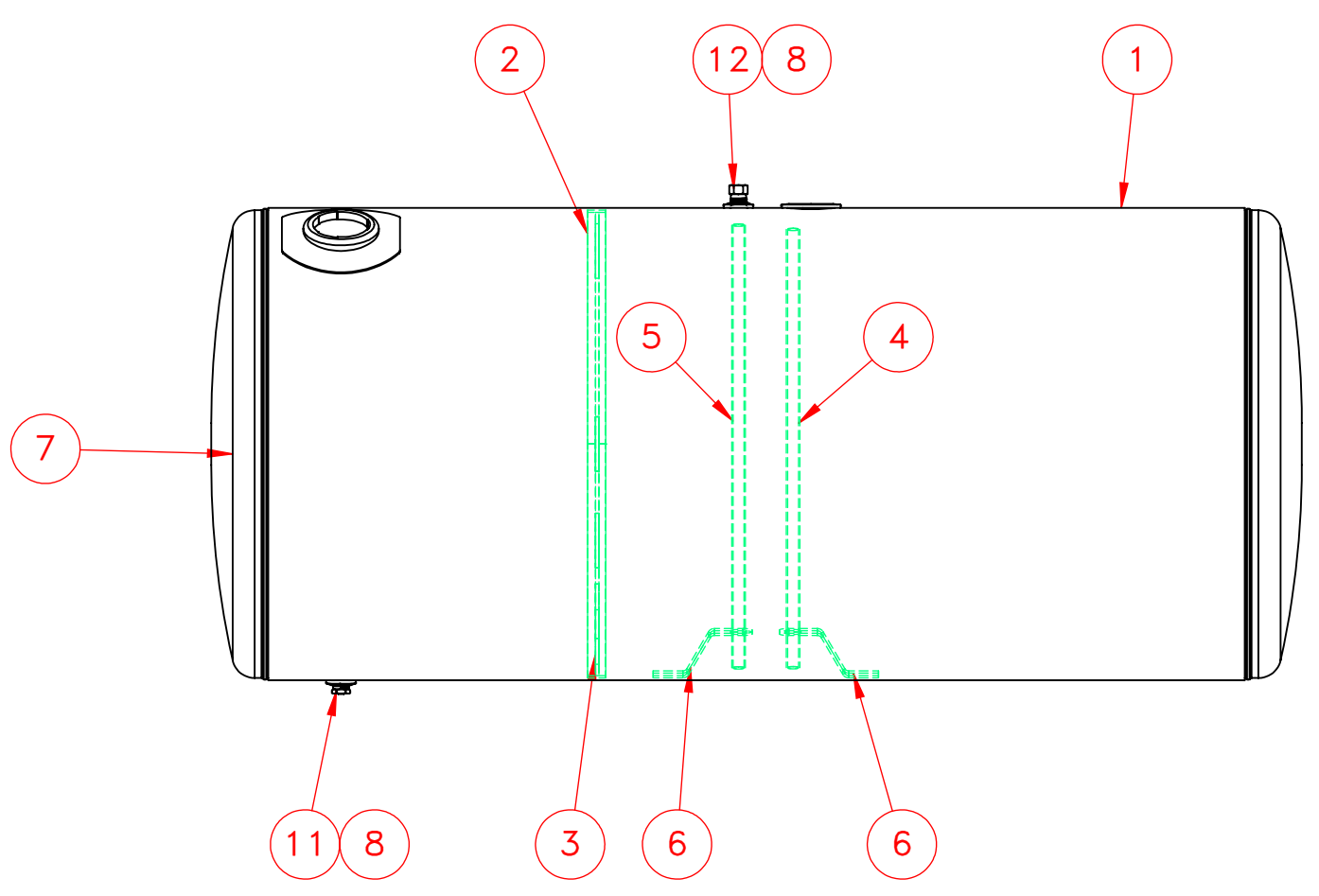

ITEM NO.	PART NUMBER	MakeOrBuy	DESCRIPTION	QTY.
1	116-1427		1/8" Auminum Wrap	1
2	266-0104		Baffle Ring	1
3	262-0076		26" Peterbilt Baffle	1
4	493-0002		1/2" NPT Down Tube	1
5	493-0003		3/8" NPT Down Tube	1
6	490-3001		Down Tube Support	2
7	160-0109	\$	26" Aluminum Head	2
8	260-0005	\$	1/2" FNPT Aluminum weld flange	2
9	265-0010	\$	Aluminum Float Riser	1
10	316-0016	\$	Peaterbilt Filer	1
11	458-0100	\$	1/2" NPT Ball Check Drain Plug	1
12	454-0937	\$	1/2" NPT Ball Check Vent	1

PASSENGER SIDE TANK

PROPRIETARY AND CONFIDENTIAL
 THE INFORMATION CONTAINED IN THIS DRAWING IS THE SOLE PROPERTY OF PROPOWER MFG. INC. ANY REPRODUCTION IN PART OR AS A WHOLE WITHOUT THE WRITTEN PERMISSION OF PROPOWER MFG. INC. IS PROHIBITED.

UNLESS OTHERWISE SPECIFIED:	DRAWN	NAME	DATE
DIMENSIONS ARE IN INCHES	CHECKED	A.B	01/19/21
TOLERANCES:	ENG APPR.		
FRACTIONAL ± 1/16	MFG APPR.		
ANGULAR: MACH ± 1° BEND ± 1°	Q.A.		
TWO PLACE DECIMAL ± .06	COMMENTS:		
THREE PLACE DECIMAL ± .031			
INTERPRET GEOMETRIC TOLERANCING PER:			
MATERIAL	ALUMINUM		
FINISH			
DO NOT SCALE DRAWING	THIRD ANGLE PROJECTION		

PROPOWER MFG. INC.
 WINDSOR, ONTARIO, CANADA
 Ph: 519-737-1197 Fax: 519-737-1918
 TOLL FREE 1-877-741-2365 Web: metaltanks.com

TITLE:
PB-R26CFA60-J
 135 US gal DIESEL FUEL TANK

SIZE DWG. NO. REV
C 27094-2

SCALE: 1:10 WEIGHT: 82 LBS SHEET 1 OF 1