

**DETAIL A**  
**SCALE 1 : 2**

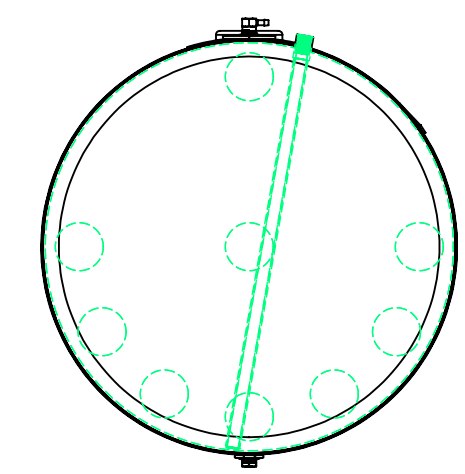
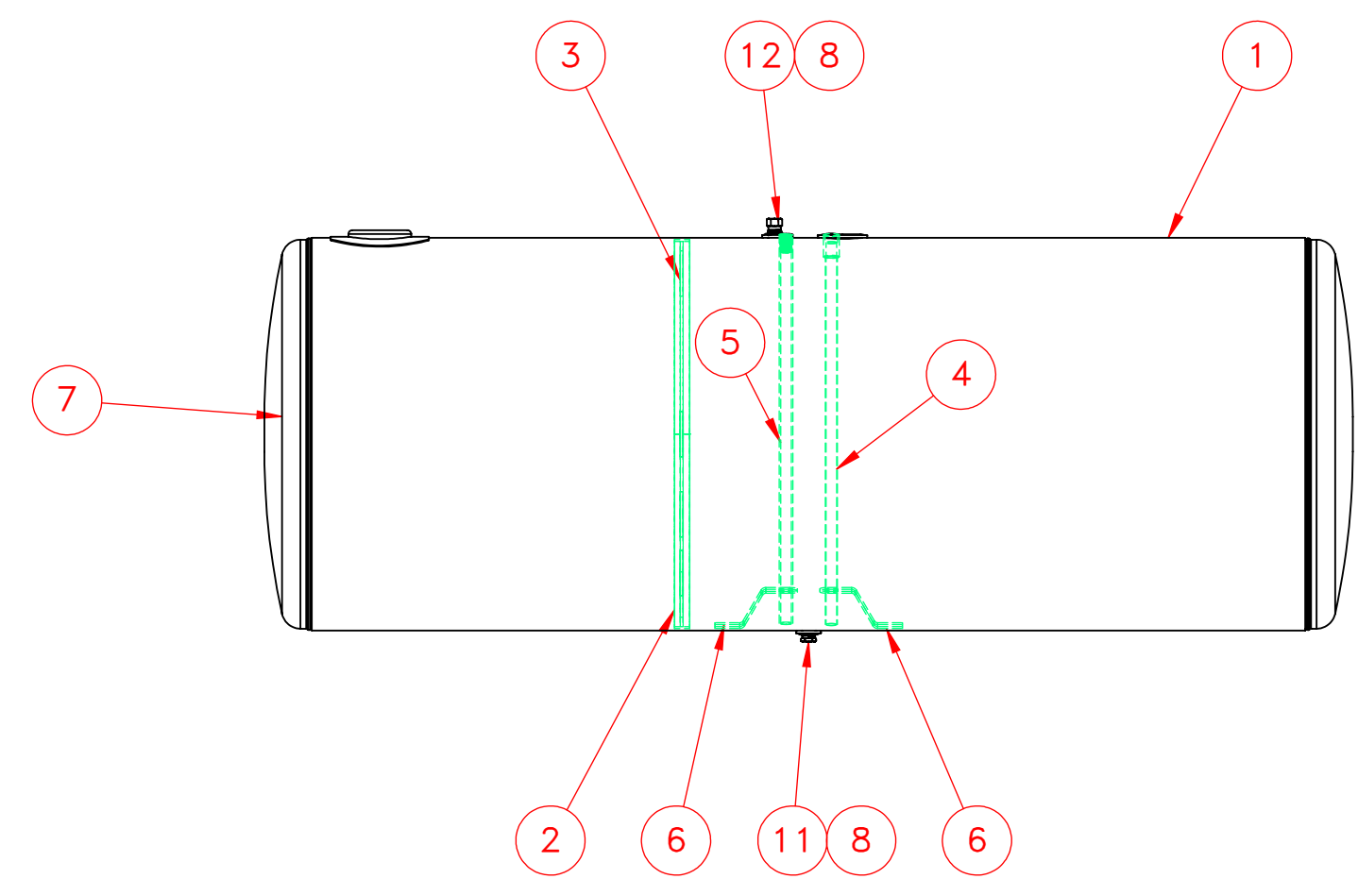
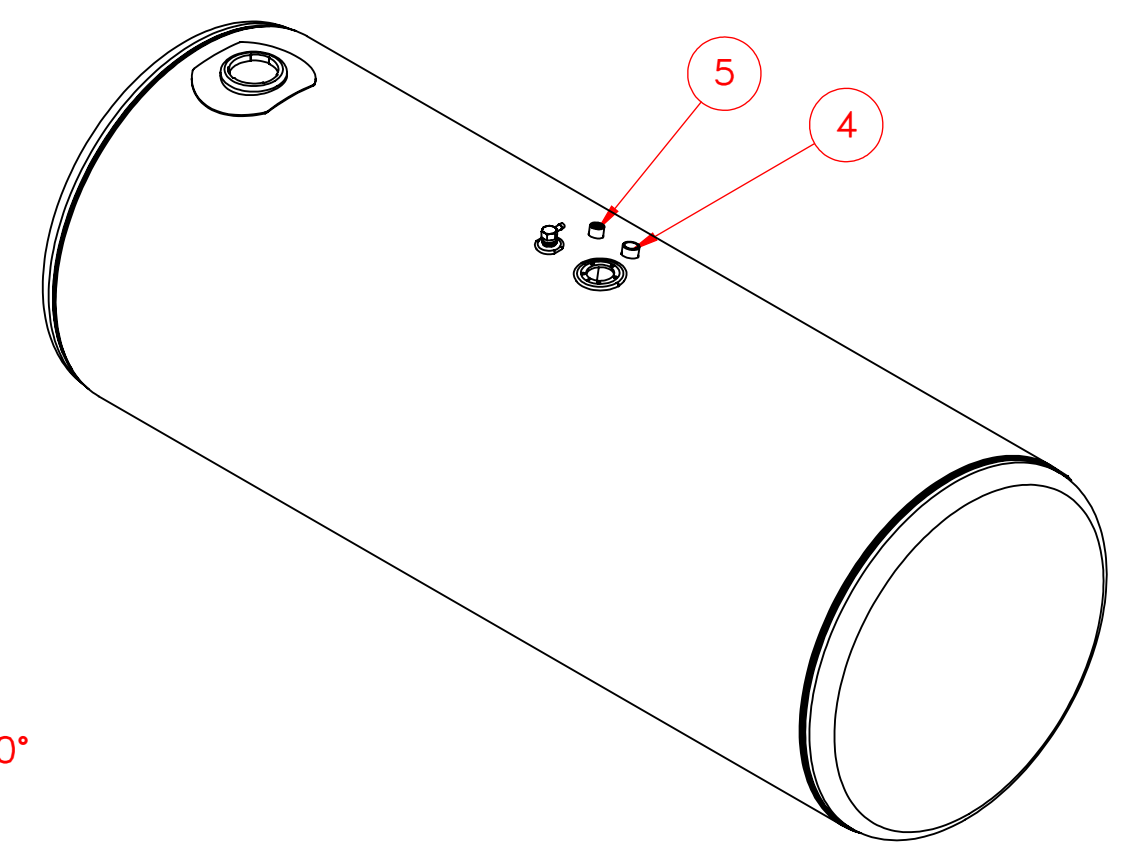

ITEM NO.	PART NUMBER	DESCRIPTION	QTY.
1	116-1314	1/8" Auminum Wrap	1
2	260-0104	Baffle Ring	1
3	262-0076	26" Peterbilt Baffle	1
4	490-0101	1/2" FNPT Down Tube	1
5	490-0104	3/8" FNPT Down Tube	1
6	490-3001	Down Tube Support	2
7	160-0109	26" Aluminum Head	2
8	260-0005	1/2" FNPT Aluminum weld flange	2
9	265-0009	Aluminum Float Riser	1
10	316-0016	Peaterbilt Filer	1
11	458-0100	1/2" NPT Ball Check Drain Plug	1
12	454-0937	1/2" NPT Ball Check Vent	1

**NOTES FOR STANDARD CONSTRUCTION:**  
 ...MEETS FMCSA REQUIREMENTS.  
 ...PRESSURE TESTED @ 5psi  
 ...INTERIOR FREE OF FOREIGN MATTER.  
 ...FULL BAFFLE(S) WHERE SHOWN  
 ...ALUMINUM CONSTRUCTION:  
 5052-H32 ALUMINUM, BRIGHT FINISH  
 HEADS & SHELL IS 0.125"  
 ...ALL OPENINGS PLUGGED PRIOR TO SHIPPING

**PROPOWER MFG. INC.**  
 WINDSOR, ONTARIO, CANADA  
 Ph: 519-737-1197 Fax: 519-737-1918  
 TOLL FREE 1-877-741-2365 Web: metaltanks.com

**TITLE:** PB-R26CFA72-K  
 159 US GROSS GALLONS  
 150 USEBLE GALLONS  
 DIESEL FUEL TANK

**SIZE DWG. NO. REV**  
**C 25858-2**

SCALE: 1:12, WEIGHT: 94 LBS SHEET 1 OF 1

UNLESS OTHERWISE SPECIFIED: DRAWN NAME DATE  
 A.B 03/12/20

CHECKED  
 ENG APPR.  
 MFG APPR.  
 Q.A.  
 COMMENTS:

INTERPRET GEOMETRIC TOLERANCING PER:  
 MATERIAL ALUMINUM  
 FINISH  
 DO NOT SCALE DRAWING

THIRD ANGLE PROJECTION

**PROPRIETARY AND CONFIDENTIAL**  
 THE INFORMATION CONTAINED IN THIS DRAWING IS THE SOLE PROPERTY OF PROPOWER MFG. INC. ANY REPRODUCTION IN PART OR AS A WHOLE WITHOUT THE WRITTEN PERMISSION OF PROPOWER MFG. INC. IS PROHIBITED.