

5X ϕ .16 THRU ALL
 10-32 UNF THRU ALL
 \checkmark ϕ .21 X 90°, NEAR SIDE

DETAIL A
SCALE 1 : 2

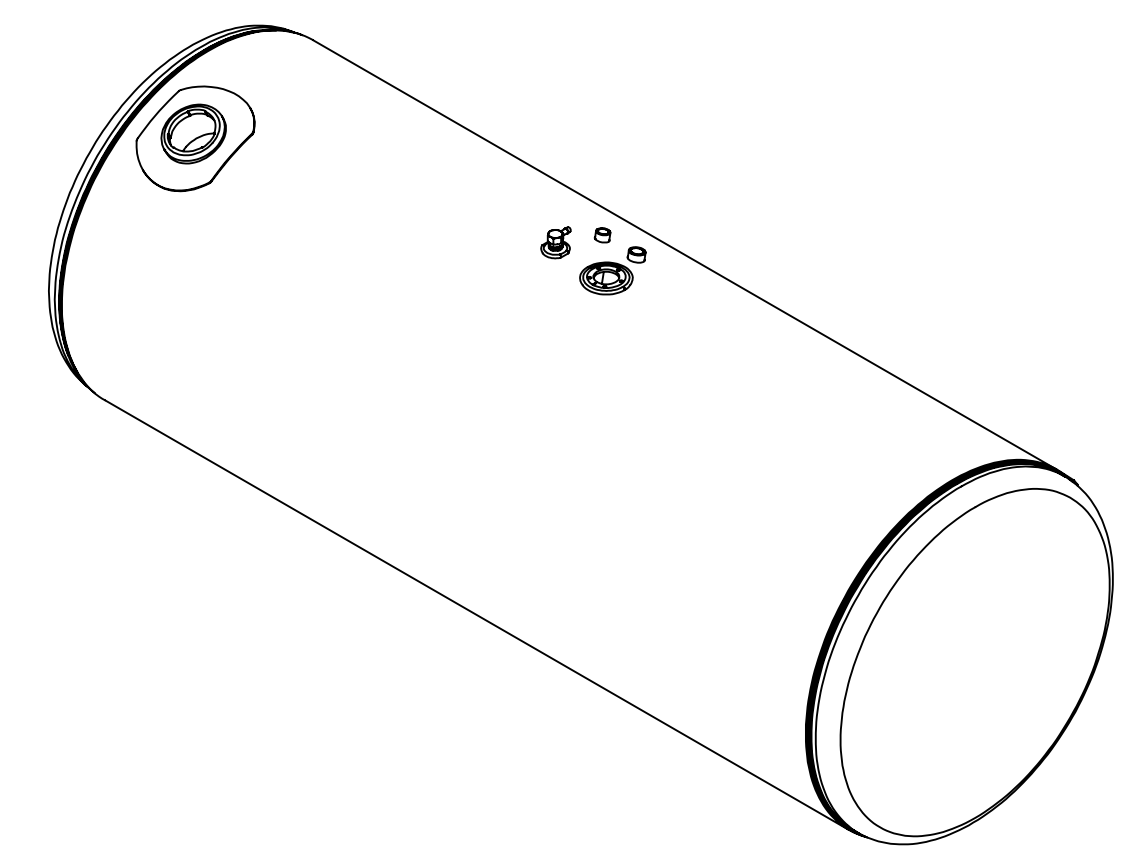

NOTES FOR STANDARD CONSTRUCTION:
 ...MEETS FMCSA REQUIREMENTS.
 ...PRESSURE TESTED @ 5psi
 ...INTERIOR FREE OF FOREIGN MATTER.
 ...FULL BAFFLE(S) WHERE SHOWN
 ...ALUMINUM CONSTRUCTION:
 5052-H32 ALUMINUM, BRIGHT FINISH
 HEADS & SHELL IS 0.125"
 ...ALL OPENINGS PLUGGED PRIOR TO SHIPPING

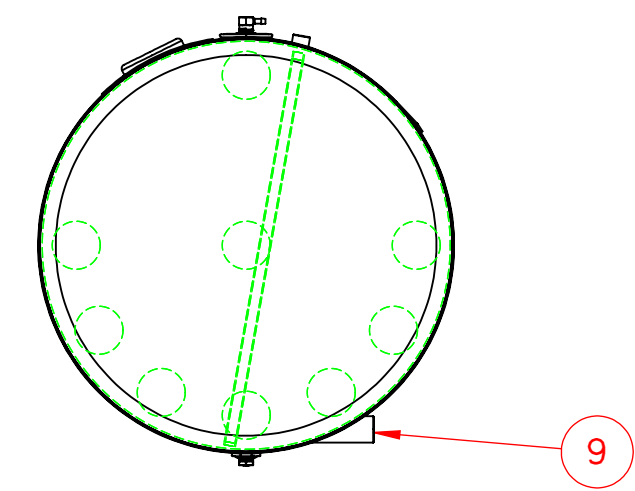
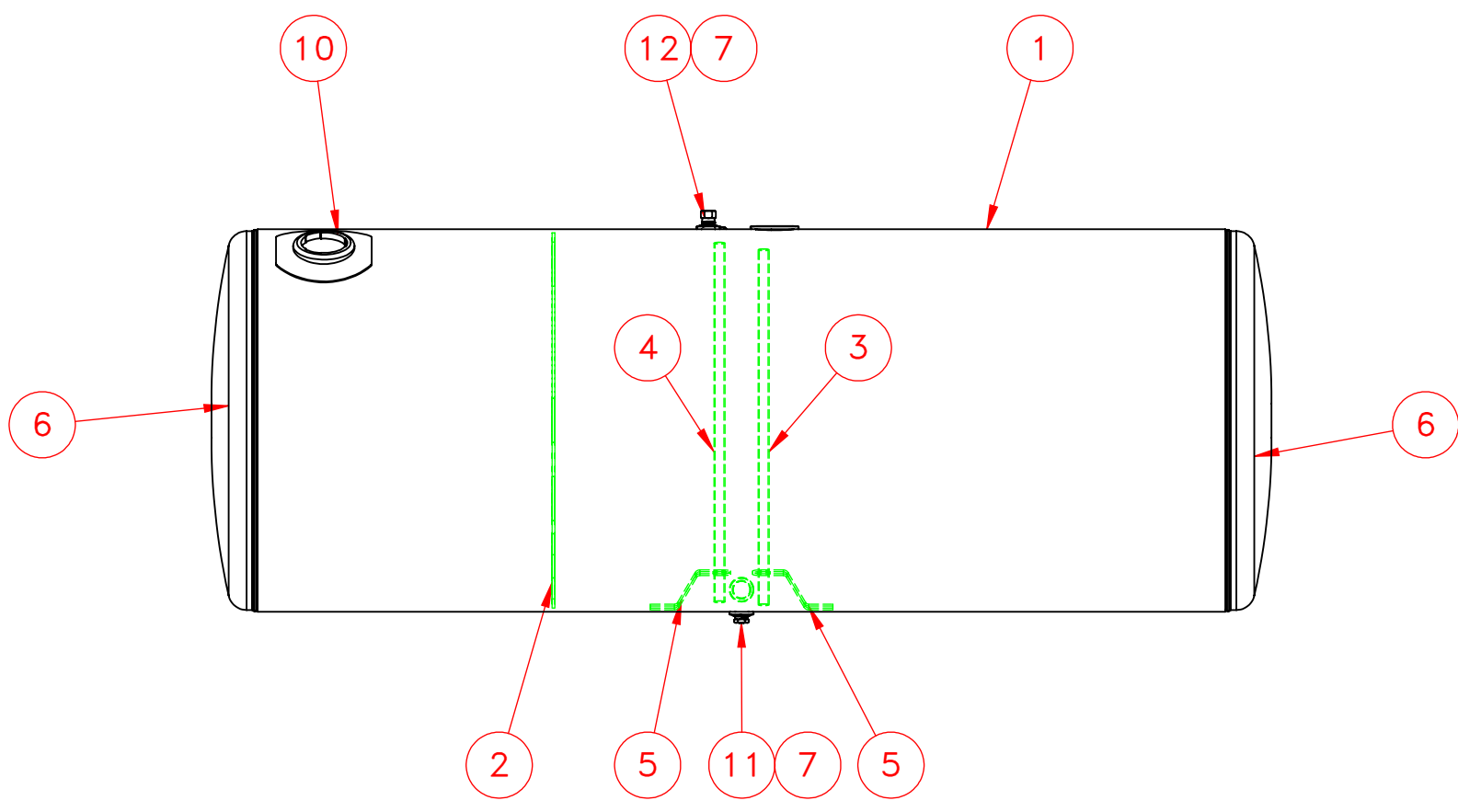

ITEM NO.	PART NUMBER	MakeOrBuy	DESCRIPTION	QTY.
1	116-1536		1/8" Auminum Wrap	1
2	267-0017		Baffle	1
3	493-0002		1/2" NPT Down Tube	1
4	493-0003		3/8" NPT Down Tube	1
5	490-3001		Down Tube Support	2
6	160-0109	\$	26" Aluminum Head	2
7	260-0005	\$	1/2" FNPT Aluminum weld flange	2
8	265-0010	\$	Aluminum Float Riser	1
9	312-0011		1" NPT Crossover	1
10	316-0016	\$	Peterbilt Filer	1
11	458-0100	\$	1/2" NPT Ball Check Drain Plug	1
12	454-0937	\$	1/2" NPT Ball Check Vent	1

UNLESS OTHERWISE SPECIFIED: DIMENSIONS ARE IN INCHES TOLERANCES: FRACTIONAL \pm 1/16 ANGULAR: MACH \pm 1° BEND \pm 1° TWO PLACE DECIMAL \pm .06 THREE PLACE DECIMAL \pm .031	DRAWN	A.B	11/04/21	PROPOWER MFG. INC. WINDSOR, ONTARIO, CANADA Ph: 519-737-1197 Fax: 519-737-1918 TOLL FREE 1877-7412365 Web: metaltanks.com
	CHECKED	Admin	11-04-21	
	ENG APPR.			
	MFG APPR.			
INTERPRET GEOMETRIC TOLERANCING PER:	MATERIAL ALUMINUM FINISH DO NOT SCALE DRAWING			TITLE: PB-R26CFA72-L 159 US GROSS GALLONS 150 USABLE GALLONS DIESEL FUEL TANK
PROPRIETARY AND CONFIDENTIAL THE INFORMATION CONTAINED IN THIS DRAWING IS THE SOLE PROPERTY OF PROPOWER MFG. INC. ANY REPRODUCTION IN PART OR AS A WHOLE WITHOUT THE WRITTEN PERMISSION OF PROPOWER MFG. INC. IS PROHIBITED.	COMMENTS: THIRD ANGLE PROJECTION			SIZE DWG. NO. C 27981 REV SCALE: 1:12 WEIGHT: 94 LBS SHEET 1 OF 1