

NOTES FOR STANDARD CONSTRUCTION:
 ...MEETS FMCSA REQUIREMENTS.
 ...PRESSURE TESTED @ 5psi
 ...INTERIOR FREE OF FOREIGN MATTER.
 ...FILLER CAP, DRAIN PLUG & VENT PROVIDED.
 ...ALUMINUM CONSTRUCTION:
 5052-H32 ALUMINUM, BRIGHT FINISH
 HEADS ARE 0.100" & SHELL IS 0.125"
 ...ALL OPENINGS PLUGGED PRIOR TO SHIPPING

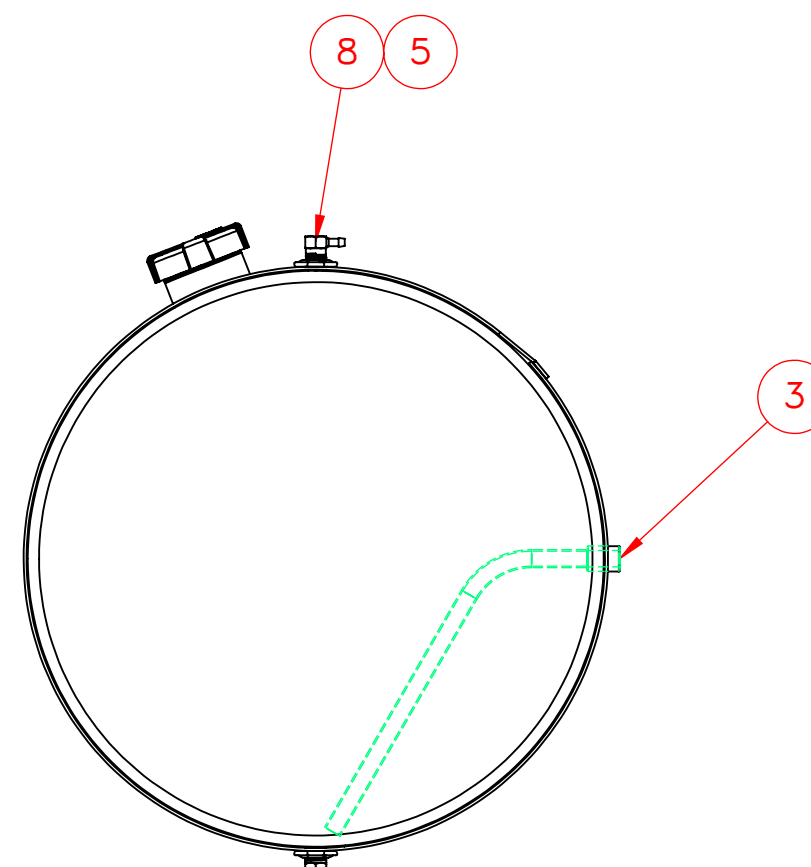
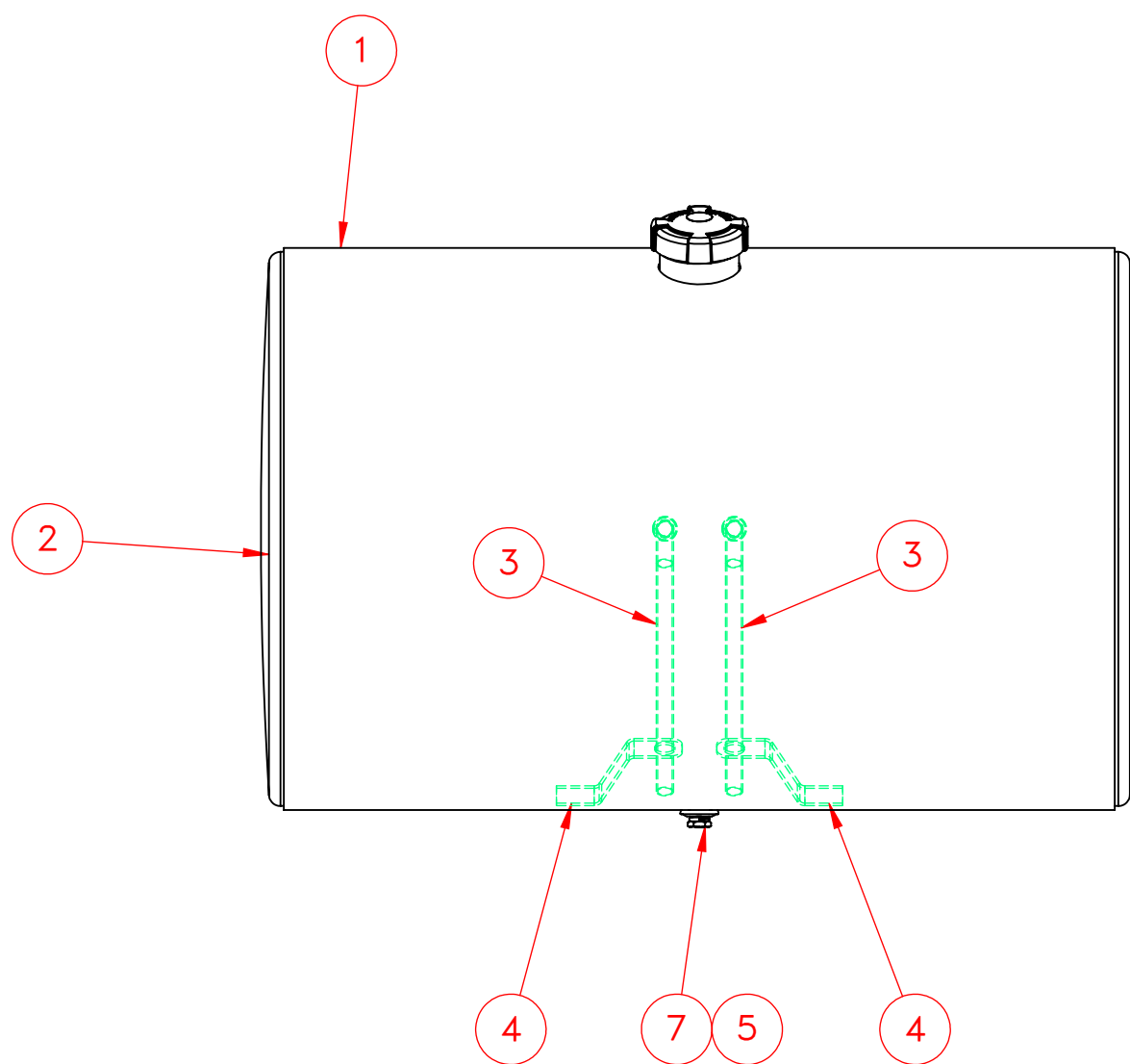

ITEM NO.	PART NUMBER	DESCRIPTION	QTY.
1	116-1336	1/8" Aluminum Wrap	1
2	160-0054	24" Head 0.100" Aluminum	2
3	490-0115	1/2" NPT Coupling With Down Tube	2
4	490-3001	Down Tube Support	2
5	260-0005	1/2" FNPT Aluminum weld flange	2
6	316-0014	3" Aluminum Filler Neck	1
7	458-0100	1/2" NPT Ball Check Drain Plug	1
8	454-0937	1/2" NPT Ball Check Vent	1
9	452-1628	Fuel Cap 3" Pressure Relief	1

UNLESS OTHERWISE SPECIFIED: DIMENSIONS ARE IN INCHES TOLERANCES: FRACTIONAL ± 1/16 ANGULAR: MACH ± 1° BEND ± 1° TWO PLACE DECIMAL ± .06 THREE PLACE DECIMAL ± .031	DRAWN	NAME	DATE	PROPOWER MFG. INC. WINDSOR, ONTARIO, CANADA Ph: 519-737-1197 Fax: 519-737-1918 TOLL FREE 1-877-741-2365 Web: metaltanks.com
	CHECKED	A.B	05/29/20	
	ENG APPR.			
	MFG APPR.			
INTERPRET GEOMETRIC TOLERANCING PER: MATERIAL ALUMINUM FINISH DO NOT SCALE DRAWING	COMMENTS: THIRD ANGLE PROJECTION	TITLE: ST-24CFA38 75 US gal DIESEL FUEL TANK	SIZE DWG. NO. C 26168 REV	SCALE: 1:8 WEIGHT: 56 LBS SHEET 1 OF 1

PROPRIETARY AND CONFIDENTIAL
 THE INFORMATION CONTAINED IN THIS DRAWING IS THE SOLE PROPERTY OF PROPOWER MFG. INC. ANY REPRODUCTION IN PART OR AS A WHOLE WITHOUT THE WRITTEN PERMISSION OF PROPOWER MFG. INC. IS PROHIBITED.