

5X ϕ .16 THRU ALL
 10-32 UNF THRU ALL
 \checkmark ϕ .21 X 90°, NEAR SIDE

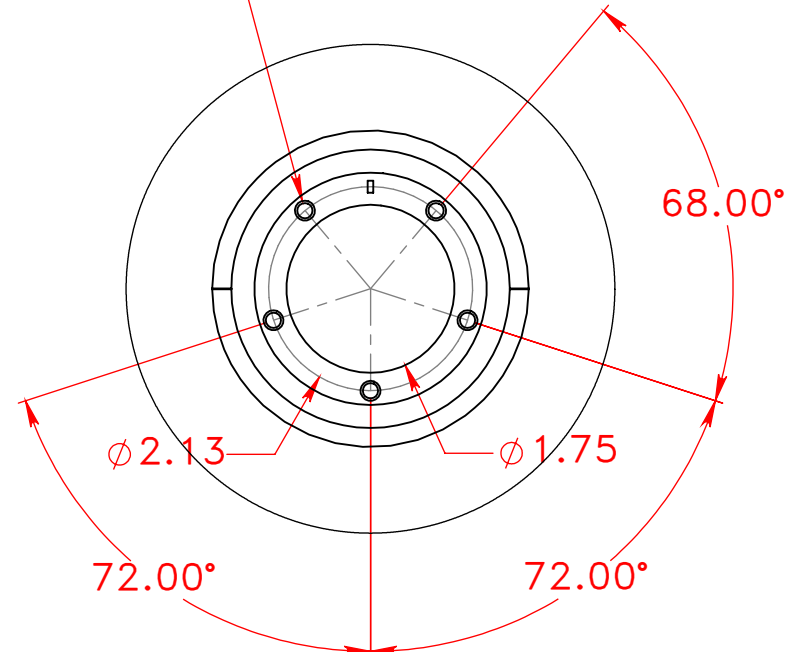

DETAIL A
 SCALE 1 : 2

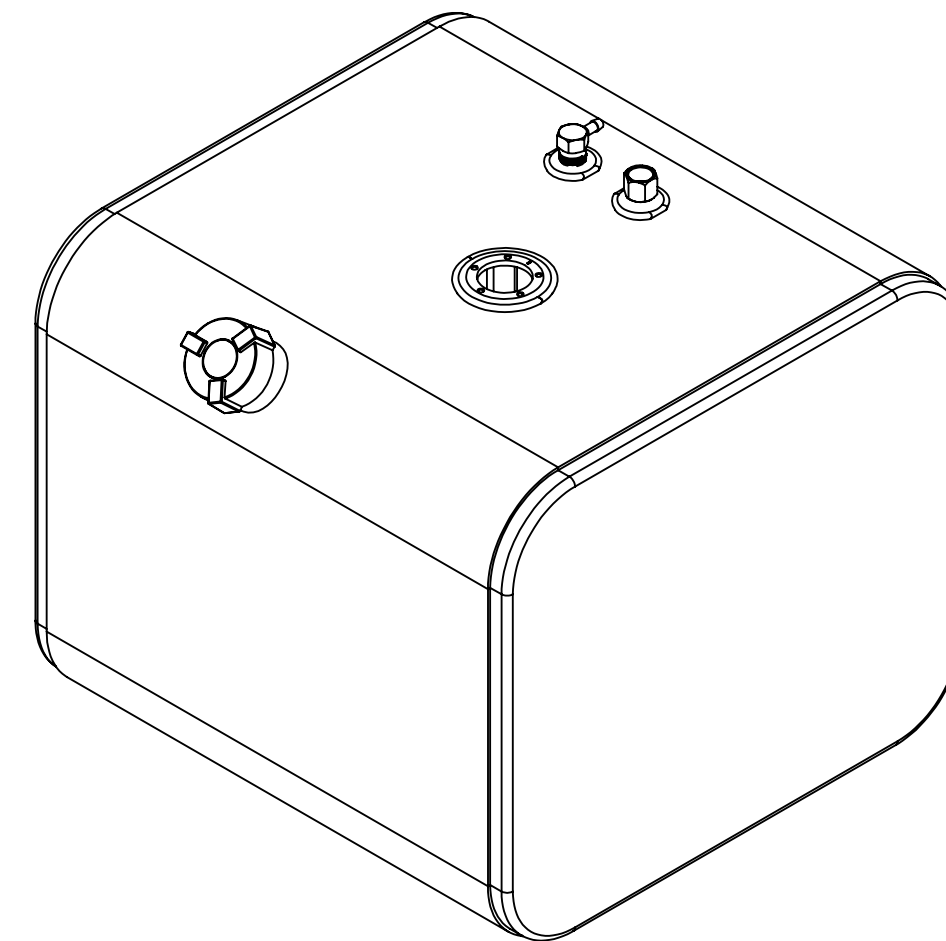

NOTES FOR STANDARD CONSTRUCTION:
 ...PRESSURE TESTED @ 5psi PER FMCSA
 ...INTERIOR FREE OF FOREIGN MATTER.
 ...FILLER CAP, DRAIN PLUG, DRAW TUB & VENT PROVIDED.
 ...STEEL CONSTRUCTION 12ga HRPO
 ...STEEL FINISH;
 SEMI-GLOSS BLACK ENAMEL APPLIED.
 ...ALL OPENINGS PLUGGED & THE INTERIOR FOGGED
 WITH ANTI-CORROSION OIL PRIOR TO SHIPPING

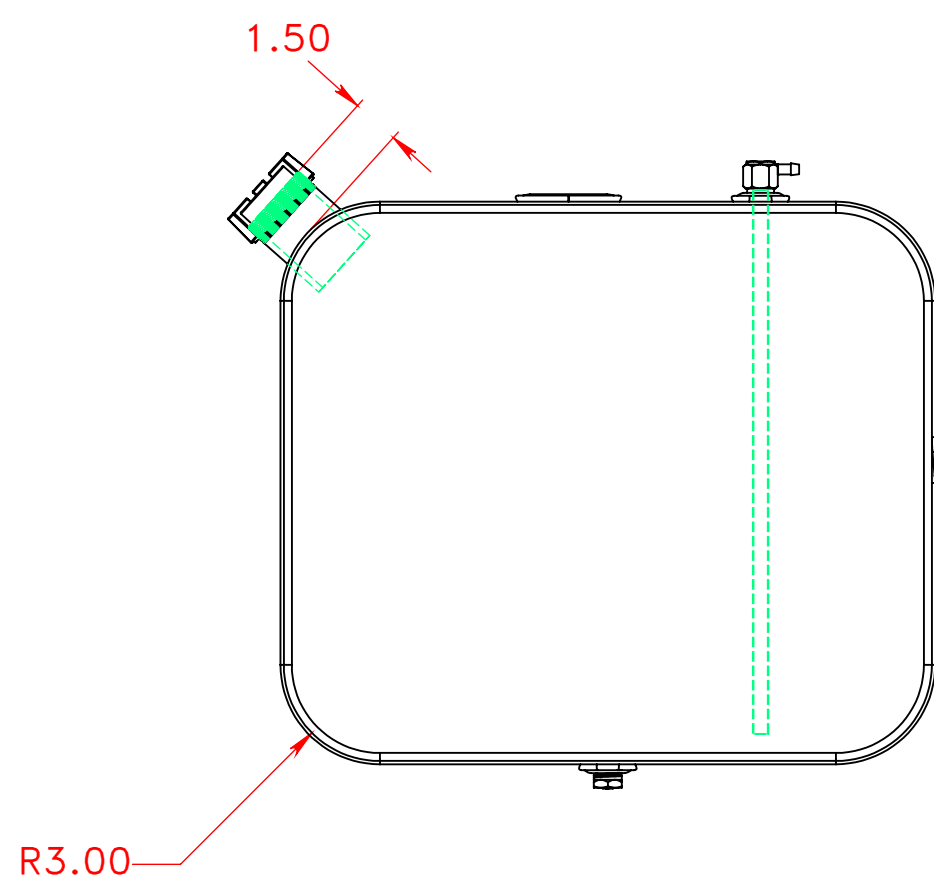
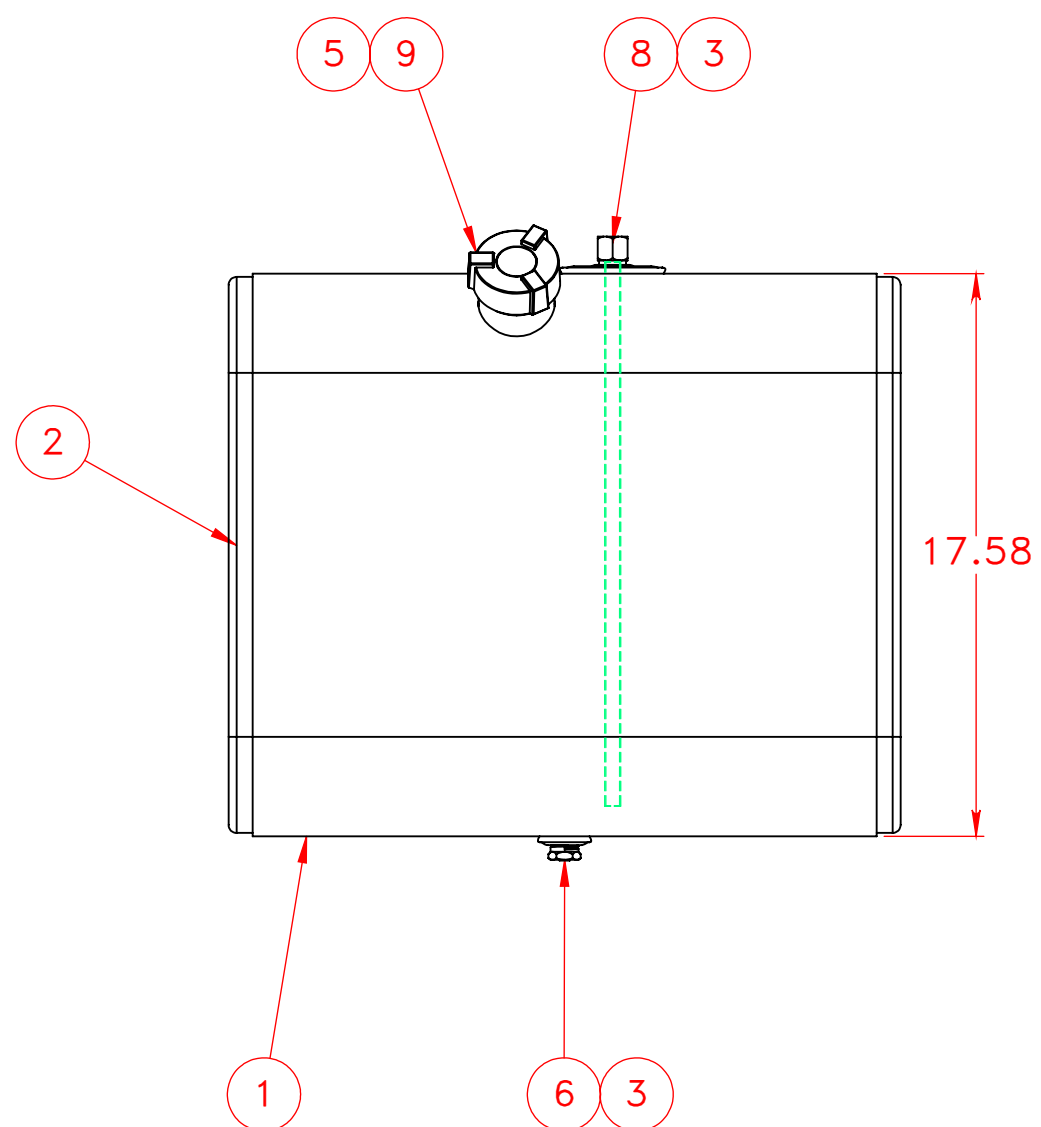

ITEM NO.	PART NUMBER	DESCRIPTION	QTY.
1	126-0833	12 ga HRPO Steel Wrap	1
2	170-0015	17x20 Head	2
3	270-0007	1/2" FNPT Steel weld flange	3
4	275-0002	Steel Float Riser	1
5	326-0001	2" Steel Filler Neck	1
6	458-0100	1/2" NPT Ball Check Drain Plug	1
7	454-0937	1/2" NPT Ball Check Vent	1
8	490-0017-Z	1/2" NPT Down Tube	1
9	452-0998	2" Thermal Relief Fuel Cap	1

UNLESS OTHERWISE SPECIFIED: DIMENSIONS ARE IN INCHES TOLERANCES: FRACTIONAL \pm 1/16 ANGULAR: MACH \pm 1° BEND \pm 1° TWO PLACE DECIMAL \pm .06 THREE PLACE DECIMAL \pm .031	DRAWN	NAME	DATE	PROPOWER MFG. INC. WINDSOR, ONTARIO, CANADA Ph: 519-737-1197 Fax: 519-737-1918 TOLL FREE 1-877-741-2365 Web: metaltanks.com
	CHECKED	A.B	09/16/19	
	ENG APPR.			
	MFG APPR.			
INTERPRET GEOMETRIC TOLERANCING PER:	COMMENTS:			TITLE: ST-L17-20RF21 34 US GROSS GALLONS 32 USEBLE GALLONS DIESEL FUEL TANK
MATERIAL	HRPO STEEL			
FINISH				
DO NOT SCALE DRAWING	THIRD ANGLE PROJECTION			SIZE DWG. NO. REV C 25425-1
SCALE: 1:6 WEIGHT: 68 LBS SHEET 1 OF 1				

PROPRIETARY AND CONFIDENTIAL
 THE INFORMATION CONTAINED IN THIS DRAWING IS THE SOLE PROPERTY OF PROPOWER MFG. INC. ANY REPRODUCTION IN PART OR AS A WHOLE WITHOUT THE WRITTEN PERMISSION OF PROPOWER MFG. INC. IS PROHIBITED.