

5X ϕ .16 THRU ALL
 10-32 UNF THRU ALL
 \checkmark ϕ .21 X 90°, NEAR SIDE

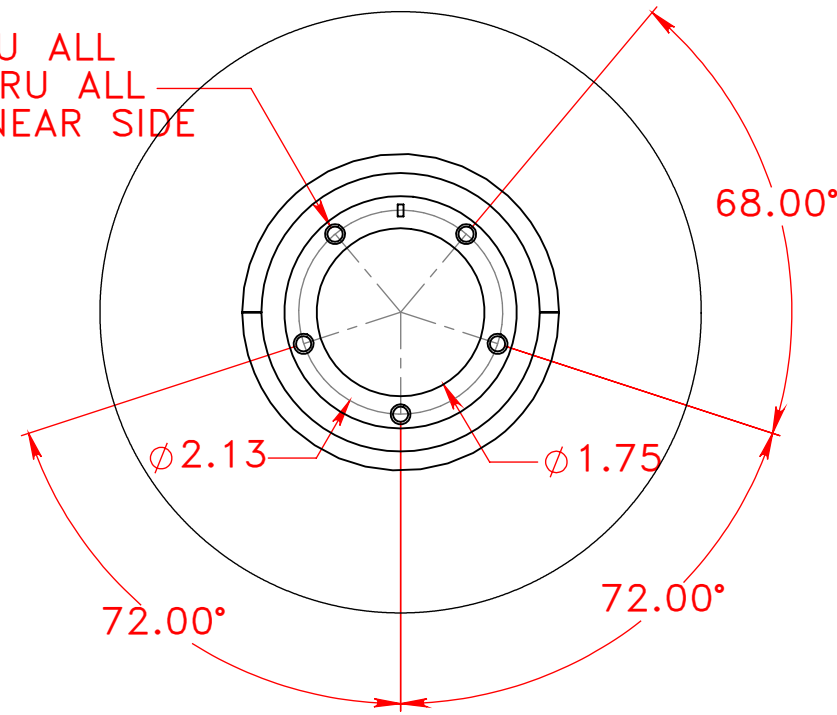

DETAIL A
 SCALE 1 : 2

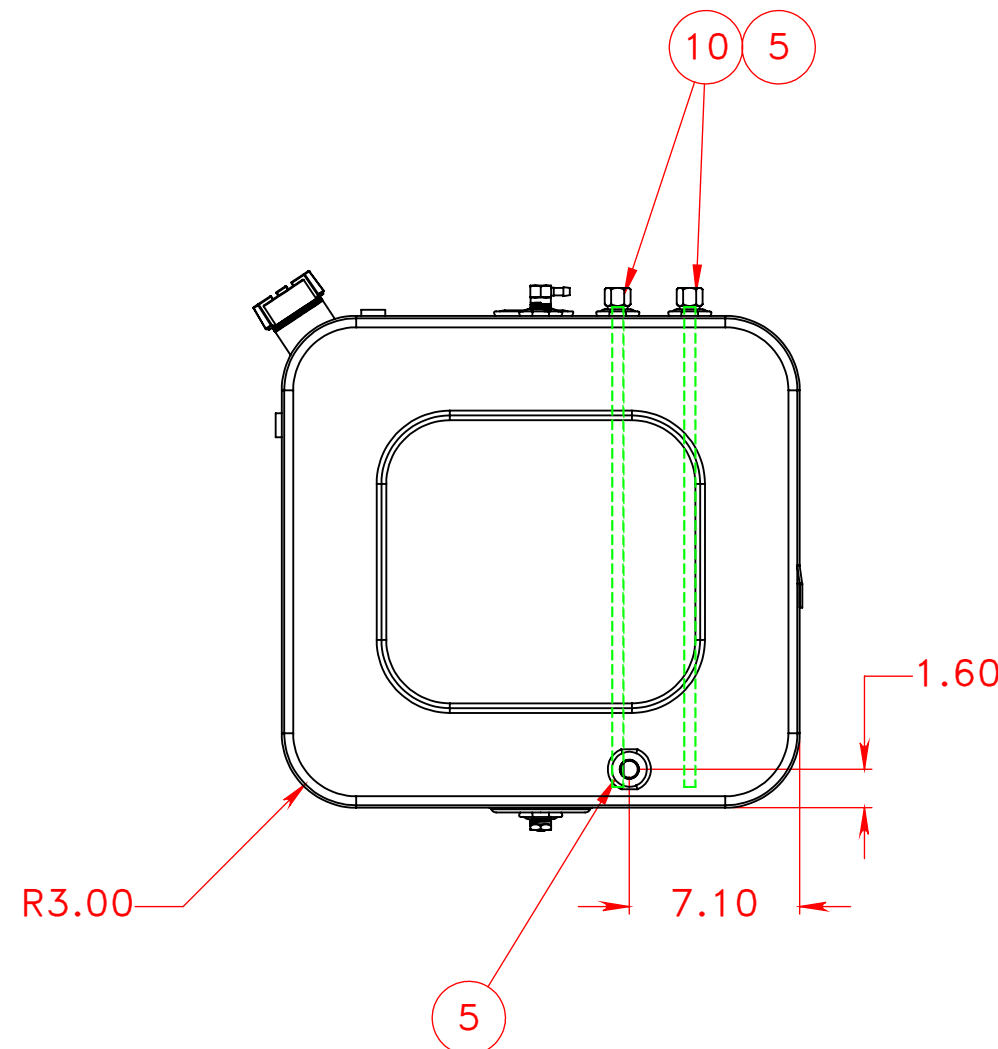
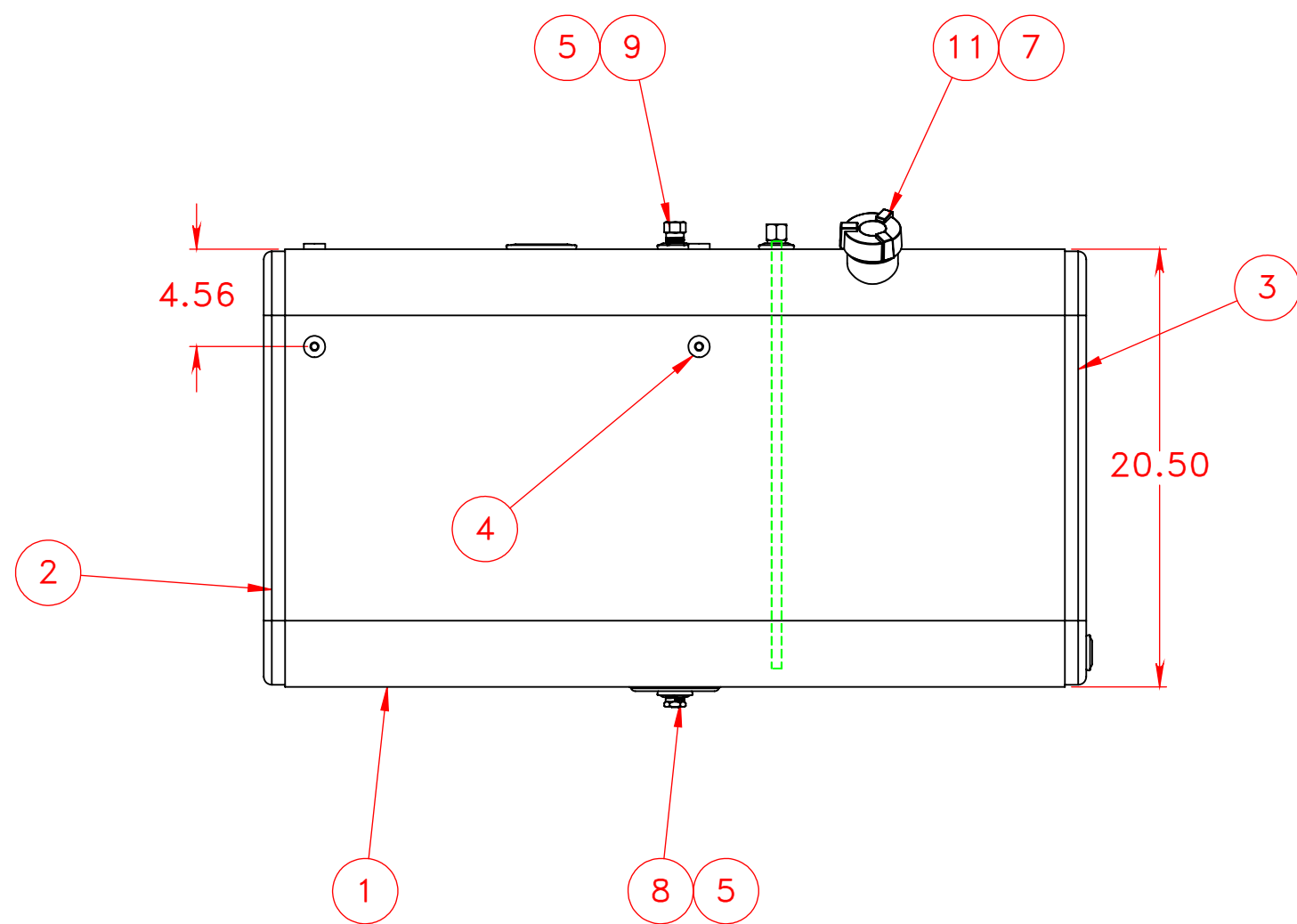
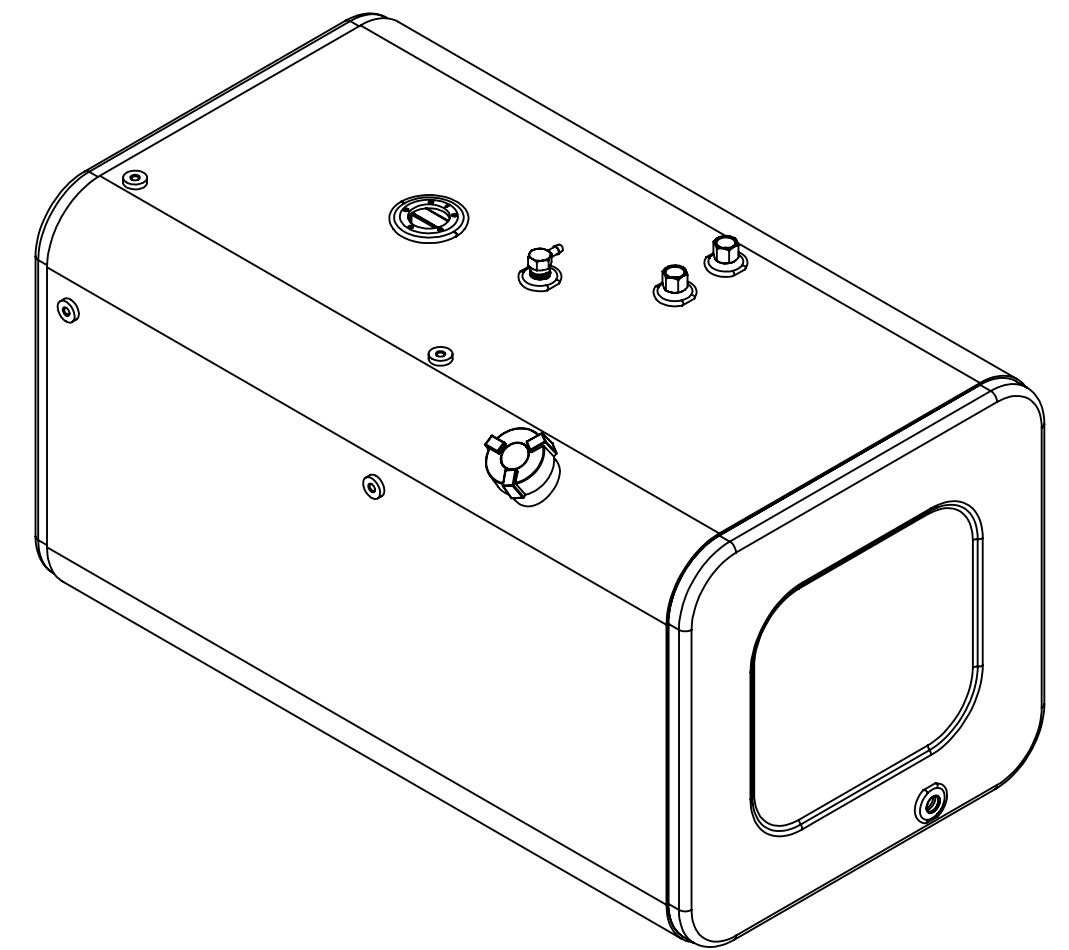

ITEM NO.	PART NUMBER	DESCRIPTION	QTY.
1	126-0513	12 ga HRPO Steel Wrap	1
2	170-0022	20.5x21.59 Head	1
3	170-0022	20.5x21.59 Head 1/2" npt Crossover	1
4	227-0001	Step Boss	4
5	270-0007	1/2" FNPT Steel weld flange	5
6	275-0002	Steel Float Riser	1
7	326-0001	2" Steel Filler Neck	1
8	458-0100	1/2" NPT Ball Check Drain Plug	1
9	454-0937	1/2" NPT Ball Check Vent	1
10	490-0020-Z	1/2" NPT Down Tube	2
11	452-0998	2" Thermal Relief Fuel Cap	1

NOTES FOR STANDARD CONSTRUCTION:

- ...PRESSURE TESTED @ 5psi PER FMCSA
- ...INTERIOR FREE OF FOREIGN MATTER.
- ...FILLER CAP, DRAIN PLUG, DRAW TUB & VENT PROVIDED.
- ...STEEL CONSTRUCTION 12ga HRPO
- ...STEEL FINISH;
 SEMI-GLOSS BLACK ENAMEL APPLIED.
- ...ALL OPENINGS PLUGGED & THE INTERIOR FOGGED
 WITH ANTI-CORROSION OIL PRIOR TO SHIPPING

PROPRIETARY AND CONFIDENTIAL
 THE INFORMATION CONTAINED IN THIS
 DRAWING IS THE SOLE PROPERTY OF
 PROPOWER MFG. INC. ANY
 REPRODUCTION IN PART OR AS A WHOLE
 WITHOUT THE WRITTEN PERMISSION OF
 PROPOWER MFG. INC. IS PROHIBITED.

UNLESS OTHERWISE SPECIFIED:	DRAWN	NAME	DATE
DIMENSIONS ARE IN INCHES	CHECKED	A.B	11/03/15
TOLERANCES:	ENG APPR.		
FRACTIONAL \pm 1/16	MFG APPR.		
ANGULAR: MACH \pm 1° BEND \pm 1°	Q.A.		
TWO PLACE DECIMAL \pm .06	COMMENTS:		
THREE PLACE DECIMAL \pm .031			
INTERPRET GEOMETRIC TOLERANCING PER:			
MATERIAL	HRPO STEEL		
FINISH			
DO NOT SCALE DRAWING	THIRD ANGLE PROJECTION		

PROPOWER MFG. INC. WINDSOR, ONTARIO, CANADA Ph: 519-737-1197 Fax: 519-737-1918 TOLL FREE 1-877-741-2365 Web: metaltanks.com		
TITLE: ST-L21-22RFS38-A 75usg DIESEL FUEL TANK		
SIZE	DWG. NO.	REV
C	19562	
SCALE: 1:8 WEIGHT: 118 LBS SHEET 1 OF 2		