

5X ϕ .16 THRU ALL
 10-32 UNF THRU ALL
 \checkmark ϕ .21 X 90°, NEAR SIDE

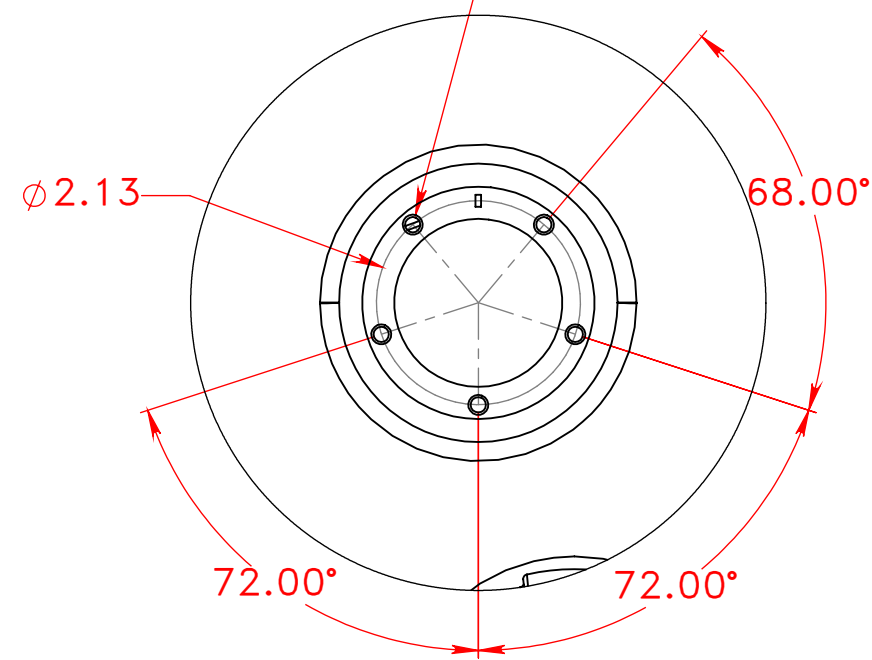

DETAIL A
 SCALE 1 : 2

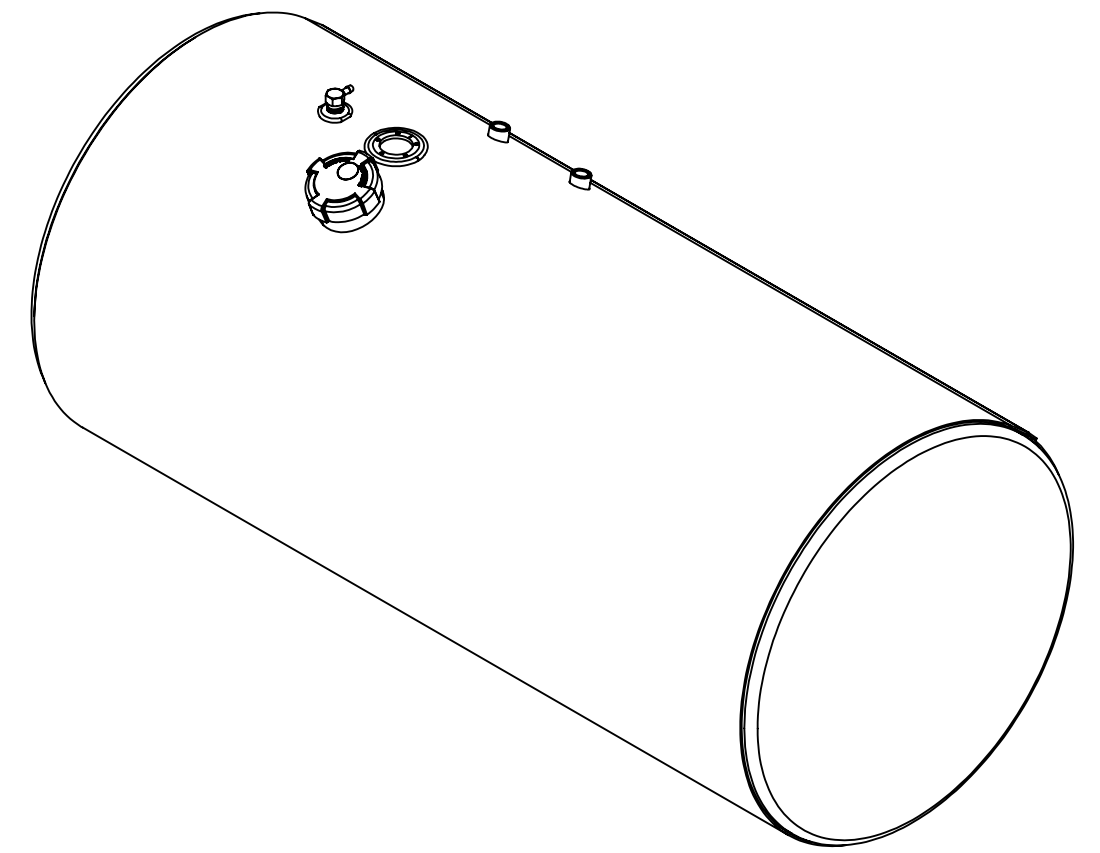

NOTES FOR STANDARD CONSTRUCTION:

- ...PRESSURE TESTED @ 5psi PER FMCSA
- ...INTERIOR FREE OF FOREIGN MATTER.
- ...FILLER CAP, DRAIN PLUG, DRAW TUB & VENT PROVIDED.
- ...STEEL CONSTRUCTION 12ga HRPO
- ...STEEL FINISH;
- ...JET BLACK POWDER COAT APPLIED.
- ...ALL OPENINGS PLUGGED & THE INTERIOR FOGGED WITH ANTI-CORROSION OIL PRIOR TO SHIPPING

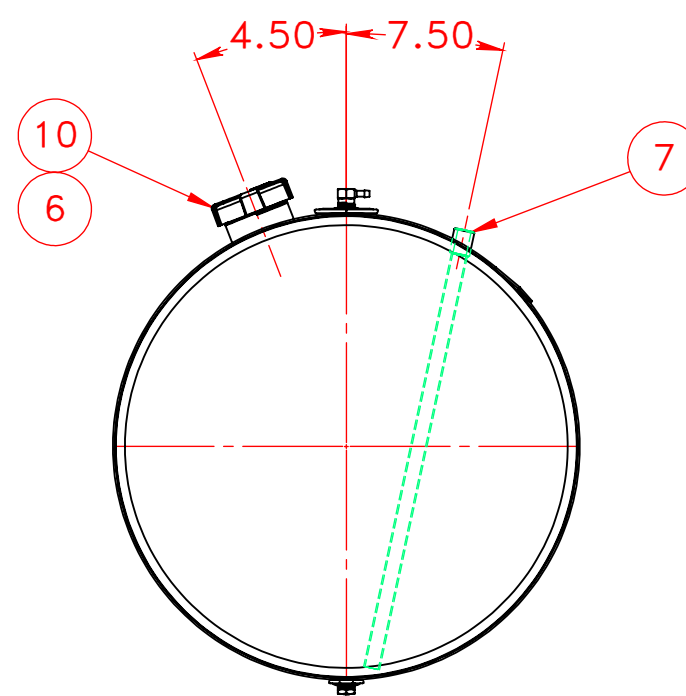
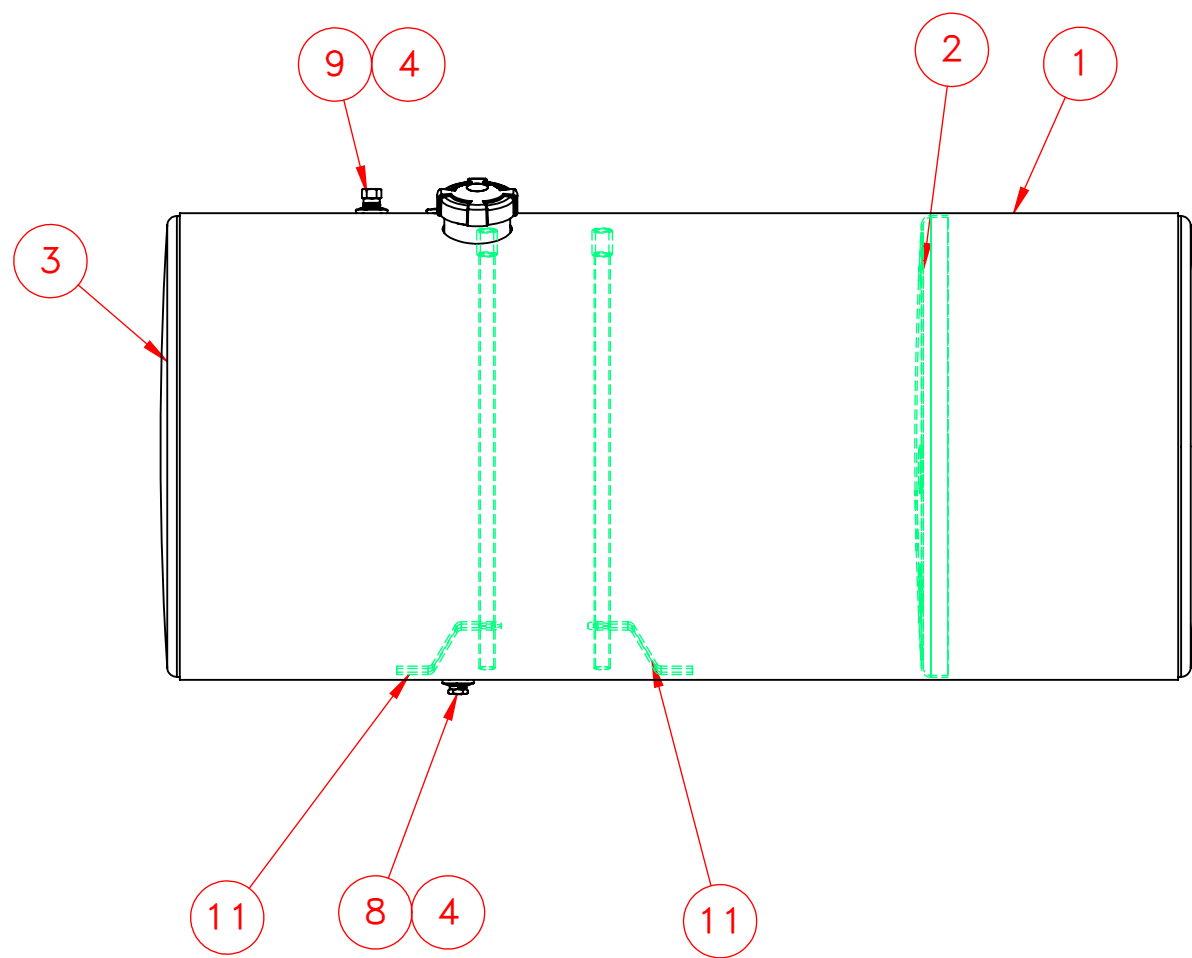

ITEM NO.	PART NUMBER	DESCRIPTION	QTY.
1	126-0092	12 ga HRPO Steel Wrap	1
2	172-0054	24" Steel Baffle	1
3	170-0054	24" Steel Head	2
4	270-0007	1/2" FNPT Steel weld flange	2
5	275-0003	Float-Riser	1
6	326-0010	3" Filler Neck	1
7	490-1000	1/2" NPT Coupling With Down Tube	2
8	458-0100	1/2" NPT Ball Check Drain Plug	1
9	454-0937	1/2" NPT Ball Check Vent	1
10	452-1628	Fuel Cap 3" Pressure Relief	1
11	490-2001	Down Tube Support	2

PROPRIETARY AND CONFIDENTIAL
 THE INFORMATION CONTAINED IN THIS DRAWING IS THE SOLE PROPERTY OF PROPOWER MFG. INC. ANY REPRODUCTION IN PART OR AS A WHOLE WITHOUT THE WRITTEN PERMISSION OF PROPOWER MFG. INC. IS PROHIBITED.

UNLESS OTHERWISE SPECIFIED:	DRAWN	NAME	DATE
DIMENSIONS ARE IN INCHES	CHECKED	A.B	08/09/11
TOLERANCES:	ENG APPR.		
FRACTIONAL \pm 1/16	MFG APPR.		
ANGULAR: MACH \pm 1° BEND \pm 1°	Q.A.		
TWO PLACE DECIMAL \pm .06	COMMENTS:		
THREE PLACE DECIMAL \pm .031			
INTERPRET GEOMETRIC TOLERANCING PER:			
MATERIAL			
HRPO STEEL			
FINISH			
DO NOT SCALE DRAWING	THIRD ANGLE PROJECTION		

PROPOWER MFG. INC.
 WINDSOR, ONTARIO, CANADA
 Ph: 519-737-1197 Fax: 519-737-1918
 TOLL FREE 1-877-741-12365 Web: metaltanks.com

TITLE:
ST-L24CF54
 106 US GROSS GALLONS
 100 USEBLE GALLONS
 DIESEL FUEL TANK

SIZE DWG. NO. REV
C 12714

SCALE: 1:10 WEIGHT: 195 LBS SHEET 1 OF 2